

PRELIMINARY

TECHNICAL SPECIFICATIONS

FHB40-55(C)(H)-E1



TCM

FHB40-55(C)(H)-E1

STANDARD SPECIFICATIONS

CHARACTERISTICS		TCM Forklifts							
1.1	Manufacturer								
1.2	Manufacturer's model designation		FHB40-E1	FHB45-E1	FHB50C-E1	FHB50-E1	FHB50H-E1	FHB55H-E1	
1.3	Power source: (battery, diesel, LPG, petrol)		Electric	Electric	Electric	Electric	Electric	Electric	
1.4	Operator type: pedestrian, (operator) - standing, - seated		Seated	Seated	Seated	Seated	Seated	Seated	
1.5	Load capacity	Q (kg)	4000	4500	4990	4990	5000	5500	
1.6	Load centre distance	c (mm)	500	500	500	500	600	600	
1.8	Load distance, axle to fork face	x (mm)	540	540	540	540	560	560	
1.9	Wheelbase	y (mm)	1946	1946	1946	2090	2090	2090	
WEIGHT									
2.1	Truck weight, without load / including battery (simple x mast, lowest lift height)	kg	7290	7648	7991	8347	8472	8711	
2.2	Axle loading with maximum load, front / rear (simple x mast, lowest lift height)	kg	10040 / 1250	10795 / 1353	11574 / 1417	11563 / 1784	12009 / 1463	12799 / 1412	
2.3	Axle loading without load, front / rear (simple x mast, lowest lift height)	kg	3902 / 3388	3890 / 3758	3902 / 4089	4075 / 4272	4234 / 4238	4246 / 4465	
WHEELS, DRIVE TRAIN									
3.1	Tyres: V = solid, L = pneumatic, SE = solid pneumatic - front / rear		SE	SE	SE	SE	SE	SE	
3.2	Tyre dimensions, front		250x15 (710)	250x15 (710)	355/50-15 (710)	355/50-15 (710)	355/50-15 (710)	355/50-15 (710)	
3.3	Tyre dimensions, rear		7.00x12 (650)	7.00x12 (650)	7.00x12 (650)	7.00x12 (650)	7.00x12 (650)	7.00x12 (650)	
3.5	Number of wheels, front / rear (x = driven)		2X / 2	2X / 2	2X / 2	2X / 2	2X / 2	2X / 2	
3.6	Track width (centre of tyres), front	b10 (mm)	1143	1143	1154	1154	1154	1154	
3.7	Track width (centre of tyres), rear	b11 (mm)	1169	1169	1169	1169	1169	1169	
DIMENSIONS									
4.1	Mast tilt, forwards / backwards	α / β °	6 / 8	6 / 8	6 / 8	6 / 8	6 / 8	6 / 8	
4.2	Height with mast lowered (see tables)	h1 (mm)	2420	2420	2420	2420	2420	2420	
4.3	Free lift (see tables)	h2 (mm)	150	150	150	150	160	160	
4.4	Lift height (see tables)	h3 (mm)	3300	3300	3300	3300	3300	3300	
4.5	Overall height with mast raised	h4 (mm)	4205	4205	4205	4205	4345	4345	
4.7	Height to top of overhead guard	h6 (mm)	2340	2340	2340	2340	2340	2340	
4.8	Seat height	h7 (mm)	1320	1320	1320	1320	1320	1320	
4.12	Tow coupling height	h10 (mm)	675	675	675	675	675	675	
4.19	Overall length	l1 (mm)	4025	4025	4025	4170	4190	4190	
4.20	Length to fork face (includes fork thickness)	l2 (mm)	2825	2825	2825	2970	2990	2990	
4.21	Overall width	b1 / b2 (mm)	1370	1370	1450	1450	1450	1450	
4.22	Fork dimensions (thickness, width, length)	s / e / l (mm)	50 / 150 / 1200	50 / 150 / 1200	50 / 150 / 1200	50 / 150 / 1200	60 / 150 / 1200	60 / 150 / 1200	
4.23	Fork carriage to DIN 15 173 A / B / no		3A	3A	3A	3A	4A	4A	
4.24	Fork carriage width	b3 (mm)	1190	1190	1190	1190	1190	1190	
4.31	Ground clearance under mast, with load	m1 (mm)	150	150	150	150	150	150	
4.32	Ground clearance at centre of wheelbase, with load (forks lowered)	m2 (mm)	150	150	150	150	150	150	
4.33	Working aisle width with 1000 x 1200 mm pallets, crosswise	Ast (mm)	4125	4125	4125	4273	4291	4291	
4.34a	Working aisle width with 800 x 1200 mm pallets, crosswise	Ast (mm)	3938	3938	3938	4086	4104	4104	
4.34b	Working aisle width with 800 x 1200 mm pallets, lengthwise	Ast (mm)	4264	4264	4264	4412	4439	4439	
4.35	Turning circle radius	Wa (mm)	2289	2289	2289	2434	2434	2434	
4.36	Minimum distance between centres of rotation	b13 (mm)	49	49	49	49	49	49	
PERFORMANCE									
5.1	Travel speed, with / without load	km / h	18 / 20	18 / 20	18 / 20	18 / 20	18 / 20	18 / 20	
5.2	Lifting speed, with / without load	m / s	0.41 / 0.53	0.38 / 0.53	0.35 / 0.53	0.35 / 0.53	0.35 / 0.53	0.32 / 0.53	
5.3	Lowering speed, with / without load	m / s	0.53 / 0.51	0.52 / 0.51	0.52 / 0.51	0.52 / 0.51	0.52 / 0.51	0.51 / 0.51	
5.5	Rated drawbar pull, with / without load	N	16000 / 16400	16800 / 17700	16800 / 17700	17600 / 18100	17500 / 17700	17600 / 18000	
5.6	Maximum drawbar pull, with / without load (5 min short duty)	N	17300 / 18400	17300 / 18400	17300 / 18400	21500 / 22600	21500 / 22600	21500 / 22600	
5.7	Gradeability, with / without load	%	15 / 23	15 / 23	14 / 22	14 / 22	13.5 / 21.5	13 / 21	
5.8	Maximum gradeability with / without load	%	15.8 / 26.6	15.6 / 23.7	14.6 / 22.6	16.6 / 28.7	16.5 / 28.2	16.4 / 27.3	
5.9	Acceleration time (10 metres) with / without load	s	4.6 / 3.9	4.7 / 3.9	4.8 / 4.0	4.6 / 4.1	4.7 / 4.1	4.8 / 4.1	
5.10	Service brakes (mechanical / hydraulic / electric / pneumatic)		hydraulic	hydraulic	hydraulic	hydraulic	hydraulic	hydraulic	
ELECTRIC MOTOR									
6.1	Drive motor capacity (60 min. short duty)	kW	2x16	2x16	2x16	2x16	2x16	2x16	
6.2	Lift motor output at 15% duty factor	kW	34	34	34	34	34	34	
6.3	Battery to DIN 43 531 / 35 / 36 A / B / C / no		DIN 43 536/A	DIN 43 536/A	DIN 43 536/A	DIN 43 536/A	DIN 43 536/A	DIN 43 536/A	
6.4	Battery voltage / capacity at 5 - hour discharge	V / Ah	80 / 775	80 / 775	80 / 775	80 / 930	80 / 930	80 / 930	
6.5	Battery weight	kg	1863	1863	1863	2178	2178	2178	
6.6a	Energy consumption according to DIN EN 16796	kWh / h	10.2 ¹⁾	10.6 ¹⁾	11.0 ¹⁾	11.2 ¹⁾	7.8 ²⁾	8.2 ²⁾	
MISCELLANEOUS									
8.1	Type of drive control		AC electronic	AC electronic	AC electronic	AC electronic	AC electronic	AC electronic	
10.1	Maximum operating pressure for attachments	bar	210	210	210	210	210	210	
10.2	Oil flow for attachments	l / min	45	45	45	45	45	45	
10.7	Noise level, value at operator's ear (EN 12053)	dB (A)	65	65	65	65	65	65	
10.8	Towing coupling, type DIN type, ref		15 170	15 170	15 170	15 170	15 170	15 170	

1) Measured with 60 cycles test. 2) Measured with 45 cycles test.

DIMENSIONS

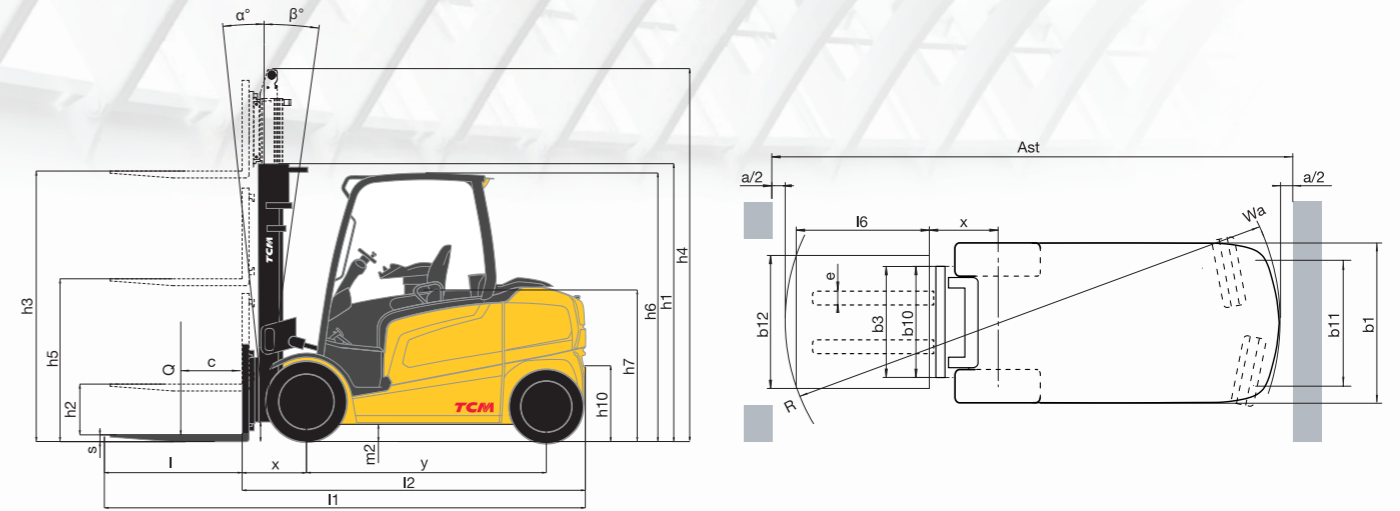

MAST SPECIFICATIONS & RATED CAPACITIES

MAST TYPE	Max fork height (mm)	Overall mast height (mm)		Free lift (mm)	Mast tilt forward / backward (degrees)		FHB40-E1		FHB45-E1		FHB50C-E1		FHB50-E1	
		Lowered	Extended		Std	Cabin	Load Capacity (kgs) @ load centre (mm)							
2 STAGE	3050	2270*	3905	150	6 - 8	6 - 8	4000	4000	4500	4500	5000	4825	5000	4825
	3350	2420*	4205	150	6 - 8	6 - 8	4000	4000	4500	4500	5000	4825	5000	4825
	3550	2520	4405	150	6 - 8	6 - 8	4000	4000	4500	4500	5000	4825	5000	4825
	3750	2620	4605	150	6 - 8	6 - 8	4000	4000	4500	4500	5000	4825	5000	4825
	4050	2870	4905	150	6 - 8	6 - 8	4000	4000	4500	4500	5000	4825	5000	4825
	4550	3120	5405	150	6 - 8	6 - 8	4000	4000	4500	4500	5000	4825	5000	4825
	5050	3370	5905	150	6 - 8	6 - 8	4000	3900	4500	4350	5000	4775	5000	4825
	5550	3620	6405	150	6 - 8	6 - 8	4000	3775	4500	4225	4975	4625	5000	4825
	6050	3870	6905	150	6 - 8	6 - 8	3925	3650	3900	3875	4775	4500	4950	4825
	3 STAGE	3750	2070*	4627	1193	6 - 8	6 - 6	4000	4000	4500	4475	5000	4825	5000
4090		2190*	4967	1313	6 - 8	6 - 6	4000	4000	4500	4475	5000	4825	5000	4825
4360		2280*	5237	1403	6 - 8	6 - 8	4000	4000	4500	4475	5000	4825	5000	4825
4550		2340*	5427	1463	6 - 8	6 - 8	4000	3975	4500	4450	5000	4825	5000	4825
4800		2420*	5677	1543	6 - 8	6 - 8	4000	3925	4500	4400	5000	4800	5000	4825
5100		2520	5977	1643	6 - 8	6 - 8	4000	3850	4500	4300	5000	4725	5000	4825
5550		2670	6427	1793	6 - 8	6 - 8	4000	3750	4500	4200	4950	4600	5000	4825
6050		2870	6927	1993	6 - 8	6 - 8	3875	3600	4025	4000	4775	4425	5000	4825
6550		3070	7427	2193	6 - 8	6 - 8	3600	3475	3075	3050	3725	3675	3900	3875
7050		3270	7927	2393	6 - 8	6 - 8	2850	2825	2425	2425	2875	2825	3075	3050

*Lower than overhead guard.

**With standard backrest: Extended height plus 207mm. 3 stage free lift minus 207mm.

MAST TYPE	Max fork height (mm)	Overall mast height (mm)		Free lift (mm)	Mast tilt forward / backward (degrees)		FHB50H-E1		FHB55H-E1	
		Lowered	Extended		Load Capacity (kgs) @ load centre (mm)					
2 STAGE	3060	2270*	4045	160	6 - 8	6 - 8	600		600	
	3360	2420*	4345	160	6 - 8	6 - 8	5000		5500	
	3560	2520	4545	160	6 - 8	6 - 8	5000		5500	
	3760	2620	4745	160	6 - 8	6 - 8	5000		5500	
	4060	2870	5045	160	6 - 8	6 - 8	5000		5500	
	4560	3120	5545	160	6 - 8	6 - 8	5000		5500	
	5060	3370	6045	160	6 - 8	6 - 8	5000		5500	
	5560	3620	6545	160	6 - 8	6 - 8	5000		5500	
	6060	3870	7045	160	6 - 8	6 - 8	4950		4725	
	3 STAGE	3760	2070*	4757	1073	6 - 8	6 - 6	5000		5500
4100		2190*	5097	1193	6 - 8	6 - 6	5000		5500	
4370		2280*	5367	1283	6 - 8	6 - 8	5000		5500	
4560		2340*	5557	1343	6 - 8	6 - 8	5000		5500	
4810		2420*	5807	1423	6 - 8	6 - 8	5000		5500	
5110		2520	6107	1523	6 - 8	6 - 8	5000		5500	
5560		2670	6557	1673	6 - 8	6 - 8	5000		5500	
6060		2870	7057	1873	6 - 8	6 - 8	5000		4775	
6560		3070	7557	2073	6 - 8	6 - 8	3800		3625	
7060		3270	8057	2273	6 - 8	6 - 8	2975</			

FHB40-55(C)(H)-E1

STANDARD AND OPTIONS LIST

	ALL MODELS
GENERAL	
4-wheel chassis, 80 volts, front wheel dual drive	●
Key pre-set economy or high performance mode (ECO / PRO)	○
3-valve hydraulic fingertip control mounted on an ergonomic armrest	●
Variable hydraulic speed control functions	●
Battery compartment side door	●
Multifunctional interactive full colour display	●
Intelligent curve control	●
Tiltable steering column	●
TruckTool setup and diagnostics	●
PDS (Seat Switch Timeout = all functions are disabled, the truck will go into the stop mode, automatically applied parking brake)	●
Full-suspension vinyl Grammer MSG65 seat	●
CE name plates -language markings	●
Operations and Maintenance Manual	●
DIN battery connectors on frame	●
Back-up drive horn button	●
Battery door detection sensor	●
Fingertip control armrest	●
Manual control levers	○
Dual Joystick	○
Mini steering wheel	○
Air conditioner	○
Heater	○
POWER SOURCE	
Integrated Li-ion battery*	○
Lead acid battery	○
FRAME	
Battery sideway exchange chassis	○
Battery roller bed	●
Battery tray	○
Battery sideway exchange tool	○
Battery inspection hatch	○
Easy charging	○
T-bar battery stand	○
LIGHTING	
LED work lights	●
Red side lines	○
Amber strobe	○
Amber strobe mounted low	○
"Blue point" rear light	○
"Blue point" rear light mounted low	○
ELECTRICAL SYSTEM	
Smart backup alarm	○
Current output	○
12V connector	○
Operator presence pedal	○
Electronic differential lock	○
Dual pedal layout	○
Drive direction selection switch on ergonomic armrest (Forward-Backward) *Only on FC controls	●
Drive direction lever in steering column (Forward-Neutral-Reverse)	○
Road light kit	○
PIN code access with start switch	○
Automated lift controls	●
Automatic tilt centering via the F2 button with FC TILT/C	○
Load weight indicator	○
OPERATOR'S CABIN	
Grammer MSG65 seat	●
Grammer MSG65 with heater	○
Grammer MSG65 with cloth upholstery	○
Grammer MSG65 with cloth upholstery and heater	○
Grammer MSG75	○
Grammer MSG75 with heater	○
Grammer MSG75 with cloth upholstery	○
Grammer MSG75 with cloth upholstery and heater	○
Backrest extension	●

	ALL MODELS
ACCESSORIES	
Rear view mirror	○
External rear view mirror	○
Dead angle mirror	○
Wide view mirror	○
A4 size paper holder	○
Camera	○
Accessory clamp	○
Fire extinguisher	○
CABIN	
Default OHG	●
Low OHG	○
Battery Inspection OHG	○
Front screen and roof with wiper / washer	○
Low front screen and roof with wiper / washer	○
Front screen and roof with wiper / washer with battery inspection	○
Safety doors	○
Delux cabin	○
EXTERIOR	
Special colour (RAL) for the frame and counterweight	○
FORKS & CARRIAGE	
Various fork lengths (1000 - 2400mm) as well as fork deletion	○
Side shifter W1000mm	○
Integrated side shifter W1000mm	○
Fork positioner+ integrated side shifter	○
Load backrest	●
HYDRAULIC SYSTEM	
3/4/5-way valve armrest-mounted fingertip control	○
3/4-way valve manual control	○
Lift Control	●
Double action FC 3 v, for clamp usage	○
Double action FC 4 v, for clamp usage	○
Double action MC 3 v, for clamp usage	○
Double action MC 4 v, for clamp usage	○
Hydraulic accumulator	○
Adjustable hydraulic pressure (for 3rd and 4th valve)	○
Food grade hydraulic oil	○
Biodegradable hydraulic oil	○
Cold area hydraulic oil VG15	○
Hot area hydraulic oil VG46	○
3-way piping	○
4-way piping	○
TYRES	
Solid Pneumatic Tyres	●
Pneumatic Tyres	○
Non-marking Solid Tyres	○
Cushion tyres	○
Solid Pneumatic Twin Tyres	○

* Li-ion battery option is available in selected regions.

KEY ● Standard ○ Option

