

PRELIMINARY

TECHNICAL SPECIFICATIONS

FB/FTB14-20(L)-E4



STANDARD SPECIFICATIONS

CHARACTERISTICS			TCM Forklifts					
1.1	Manufacturer (abbreviation)		FTB14-E4	FTB16-E4	FTB18-E4	FTB16L-E4	FTB18L-E4	FTB20L-E4
1.2	Manufacturer's model designation							
1.3	Power source: (battery, diesel, LPG, petrol)		Electric	Electric	Electric	Electric	Electric	Electric
1.4	Operator type: pedestrian, (operator) - standing, - seated		Seated	Seated	Seated	Seated	Seated	Seated
1.5	Load capacity	Q (kg)	1400	1600	1800	1600	1800	2000
1.6	Load centre distance	c (mm)	500	500	500	500	500	500
1.8	Load distance, axle to fork face	x (mm)	343	343	343	343	343	343
1.9	Wheelbase	y (mm)	1320	1320	1320	1428	1428	1428
WEIGHT								
2.1	Truck weight, without load / including battery (simple x mast, lowest lift height)	kg	2790	2966	3156	2949	3119	3342
2.2	Axle loading with maximum load, front / rear (simple x mast, lowest lift height)	kg	3688 / 502	4015 / 551	4351 / 605	4020 / 529	4333 / 586	4711 / 631
2.3	Axle loading without load, front / rear (simple x mast, lowest lift height)	kg	1394 / 1396	1393 / 1573	1401 / 1754	1476 / 1474	1471 / 1649	1509 / 1833
WHEELS, DRIVE TRAIN								
3.1	Tyres: V = solid, L = pneumatic, SE = solid pneumatic - front / rear		SE	SE	SE	SE	SE	SE
3.2	Tyre dimensions, front		18 x 7 - 8	18 x 7 - 8	18 x 7 - 8	18 x 7 - 8	18 x 7 - 8	200 / 50 - 10
3.3	Tyre dimensions, rear		140 / 55 - 9	140 / 55 - 9	140 / 55 - 9	140 / 55 - 9	140 / 55 - 9	140 / 55 - 9
3.5	Number of wheels, front / rear (x = driven)		2 x / 2	2 x / 2	2 x / 2	2 x / 2	2 x / 2	2 x / 2
3.6	Track width (centre of tyres), front	b10 (mm)	930	930	930	930	930	930
3.7	Track width (centre of tyres), rear	b11 (mm)	174	174	174	174	174	174
DIMENSIONS								
4.1	Mast tilt, forwards / backwards	α / β °	5 / 7.5	5 / 7.5	5 / 7.5	5 / 7.5	5 / 7.5	5 / 7.5
4.2	Height with mast lowered (see tables)	h1 (mm)	2125	2125	2125	2125	2125	2125
4.3	Free lift (see tables)	h2 (mm)	80	80	80	80	80	80
4.4	Lift height (see tables)	h3 (mm)	3290	3290	3290	3290	3290	3290
4.5	Overall height with mast raised	h4 (mm)	4335	4335	4335	4335	4335	4335
4.7	Height to top of overhead guard	h6 (mm)	2050	2050	2050	2050	2050	2050
4.8	Seat height	h7 (mm)	1035	1035	1035	1035	1035	1035
4.12	Tow coupling height	h10 (mm)	540	540	540	540	540	540
4.19	Overall length	l1 (mm)	2996	2996	2996	3104	3104	3119
4.20	Length to fork face (includes fork thickness)	l2 (mm)	1846	1846	1846	1954	1954	1969
4.21	Overall width	b1 / b2 (mm)	1090	1090	1090	1090	1090	1140
4.22	Fork dimensions (thickness, width, length)	s / e / l (mm)	35 x 100 x 1150	35 x 100 x 1150	35 x 100 x 1150	35 x 100 x 1150	35 x 100 x 1150	35 x 100 x 1150
4.23	Fork carriage to DIN 15 173 A / B / no		2A	2A	2A	2A	2A	2A
4.24	Fork carriage width	b3 (mm)	920	920	920	920	920	920
4.31	Ground clearance under mast, with load	m1 (mm)	95	95	95	95	95	95
4.32	Ground clearance at centre of wheelbase, with load (forks lowered)	m2 (mm)	95	95	95	95	95	95
4.33	Working aisle width with 1000 x 1200 mm pallets, crosswise	Ast (mm)	3173	3173	3173	3281	3281	3295
4.34a	Working aisle width with 800 x 1200 mm pallets, lengthwise	Ast (mm)	3296	3296	3296	3404	3404	3419
4.35	Turning circle radius	Wa (mm)	1502	1502	1502	1610	1610	1610
4.36	Minimum distance between centres of rotation	b13 (mm)	0	0	0	0	0	0
PERFORMANCE								
5.1	Travel speed, with / without load	km / h	16 / 16	16 / 16	16 / 16	16 / 16	16 / 16	16 / 16
5.2	Lifting speed, with / without load	m / s	0.55 / 0.62	0.52 / 0.62	0.46 / 0.62	0.52 / 0.62	0.46 / 0.62	0.42 / 0.62
5.3	Lowering speed, with / without load	m / s	0.56 / 0.56	0.56 / 0.56	0.56 / 0.56	0.56 / 0.56	0.56 / 0.56	0.56 / 0.56
5.5	Rated drawbar pull, with / without load	N	4900 / 5200	4900 / 5200	4800 / 5100	4900 / 5200	4800 / 5100	4700 / 5100
5.6	Maximum drawbar pull, with / without load (5 min short duty)	N	15000 / 15300	14900 / 15200	14900 / 15200	14900 / 15200	14900 / 15200	14800 / 15200
5.7	Gradeability, with / without load	%	16 / 26	15 / 25	13 / 23	15 / 25	13 / 23	12 / 21
5.8	Maximum gradeability, with / without load	%	27 / 35	27 / 35	26 / 35	27 / 35	26 / 35	24 / 35
5.9	Acceleration time (10 metres), with / without load	s	4.0 / 3.8	4.1 / 3.8	4.2 / 3.8	4.1 / 3.8	4.2 / 3.8	4.3 / 3.9
5.10	Service brakes (mechanical / hydraulic / electric / pneumatic)		Electric	Electric	Electric	Electric	Electric	Electric
ELECTRIC MOTOR								
6.1	Drive motor capacity (60 min. short duty)	kW	2 x 5.5	2 x 5.5	2 x 5.5	2 x 5.5	2 x 5.5	2 x 5.5
6.2	Lift motor output at 15% duty factor	kW	10	10	10	10	10	10
6.3	Battery to DIN 43 531 / 35 / 36 A / B / C / no		DIN 43531 A / no	DIN 43531 A / no	DIN 43531 A / no	DIN 43531 A / no	DIN 43531 A / no	DIN 43531 A / no
6.4	Battery voltage / capacity at 5 - hour discharge	V / Ah	500 - 625	500 - 625	500 - 625	625 - 750	625 - 750	625 - 750
6.5	Battery weight	kg	679	679	679	812	812	812
6.6	Energy consumption according to DIN EN 16796	kWh / h	3.7	3.9	4.2	3.9	4.2	4.5
MISCELLANEOUS								
8.1	Type of drive control		AC	AC	AC	AC	AC	AC
10.1	Maximum operating pressure for attachments	bar	210	210	210	210	210	210
10.2	Oil flow for attachments	l / min	30	30	30	30	30	30
10.7	Noise level, value at operator's ear (EN 12053)	dB (A)	65	65	65	65	65	65
10.8	Towing coupling, type DIN 15170		DIN15170 - H	DIN15170 - H	DIN15170 - H	DIN15170 - H	DIN15170 - H	DIN15170 - H

DIMENSIONS

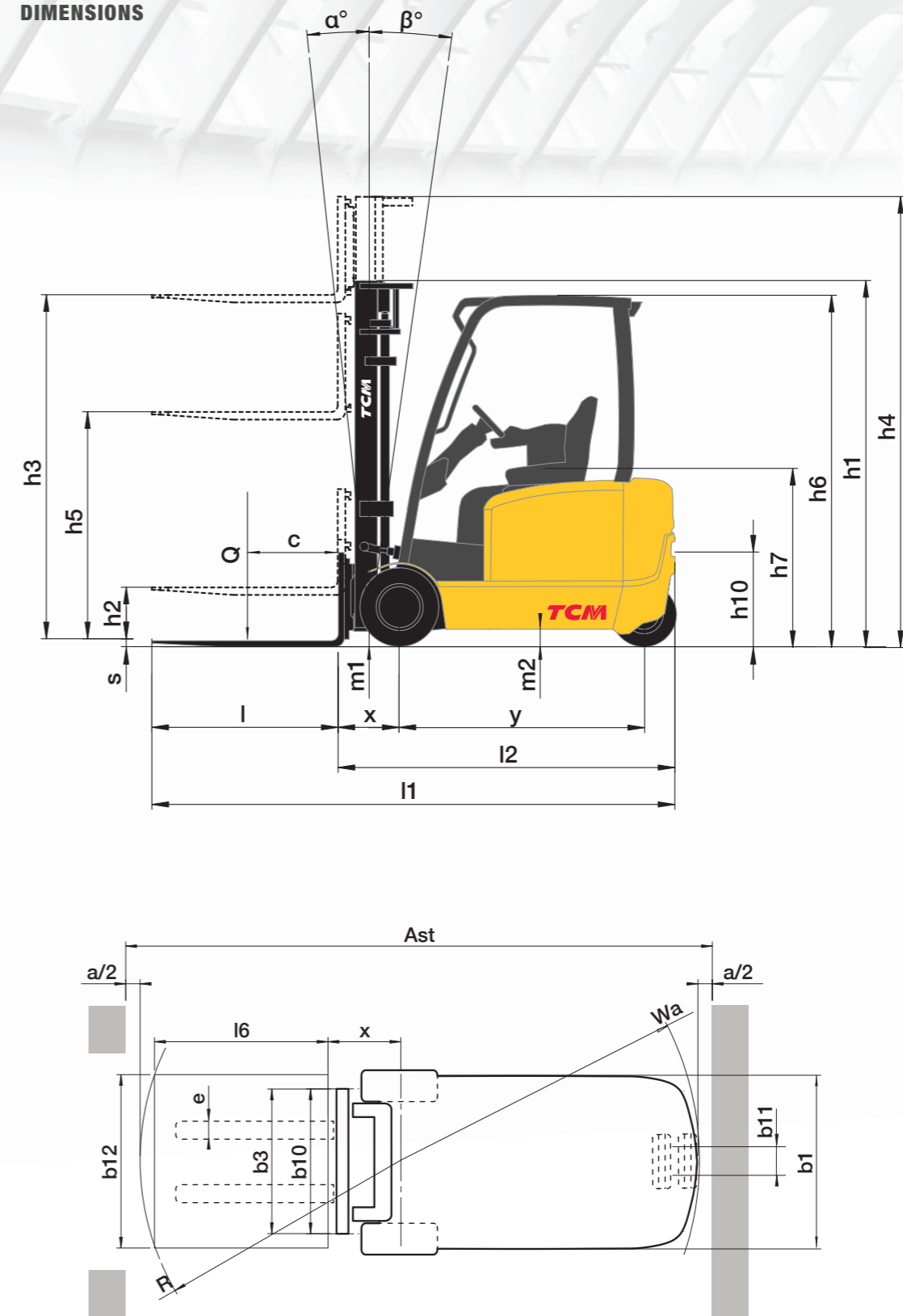

STANDARD SPECIFICATIONS

CHARACTERISTICS			TCM Forklifts				
			FB16-E4	FB18-E4	FB16L-E4	FB18L-E4	FB20L-E4
1.1	Manufacturer (abbreviation)						
1.2	Manufacturer's model designation						
1.3	Power source: (battery, diesel, LPG, petrol)		Electric	Electric	Electric	Electric	Electric
1.4	Operator type: pedestrian, (operator) - standing, - seated		Seated	Seated	Seated	Seated	Seated
1.5	Load capacity	Q (kg)	1600	1600	1600	1800	2000
1.6	Load centre distance	c (mm)	500	500	500	500	500
1.8	Load distance, axle to fork face	x (mm)	343	343	343	343	358
1.9	Wheelbase	y (mm)	1394	1394	1502	1502	1502
WEIGHT							
2.1	Truck weight, without load / including battery (simple x mast, lowest lift height)	kg	2944	3114	2957	3097	3287
2.2	Axle loading with maximum load, front / rear (simple x mast, lowest lift height)	kg	3990 / 554	4311 / 603	4008 / 550	4295 / 603	4668 / 620
2.3	Axle loading without load, front / rear (simple x mast, lowest lift height)	kg	1422 / 1522	1422 / 1522	1510 / 1448	1484 / 1613	1525 / 1762
WHEELS, DRIVE TRAIN							
3.1	Tyres: V = solid, L = pneumatic, SE = solid pneumatic - front / rear		SE	SE	SE	SE	SE
3.2	Tyre dimensions, front		18 x 7 - 8	18 x 7 - 8	18 x 7 - 8	18 x 7 - 8	200 / 50-10
3.3	Tyre dimensions, rear		16 x 6 - 8	16 x 6 - 8	16 x 6 - 8	16 x 6 - 8	16 x 6 - 8
3.5	Number of wheels, front / rear (x = driven)		2 x / 2	2 x / 2	2 x / 2	2 x / 2	2 x / 2
3.6	Track width (centre of tyres), front	b10 (mm)	930	930	930	930	938
3.7	Track width (centre of tyres), rear	b11 (mm)	898	898	898	898	898
DIMENSIONS							
4.1	Mast tilt, forwards / backwards	α / β °	5 / 7.5	5 / 7.5	5 / 7.5	5 / 7.5	5 / 7.5
4.2	Height with mast lowered (see tables)	h1 (mm)	2125	2125	2125	2125	2125
4.3	Free lift (see tables)	h2 (mm)	80	80	80	80	80
4.4	Lift height (see tables)	h3 (mm)	3290	3290	3290	3290	3290
4.5	Overall height with mast raised	h4 (mm)	4335	4335	4335	4335	4335
4.7	Height to top of overhead guard	h6 (mm)	2050	2050	2050	2050	2050
4.8	Seat height	h7 (mm)	1035	1035	1035	1035	1035
4.12	Tow coupling height	h10 (mm)	520	520	520	520	520
4.19	Overall length	l1 (mm)	3152	3152	3260	3260	3275
4.20	Length to fork face (includes fork thickness)	l2 (mm)	2002	2002	2110	2110	2125
4.21	Overall width	b1 / b2 (mm)	1090	1090	1090	1090	1140
4.22	Fork dimensions (thickness, width, length)	s / e / l (mm)	35 x 100 x 1150	35 x 100 x 1150	35 x 100 x 1150	35 x 100 x 1150	35 x 100 x 1150
4.23	Fork carriage to DIN 15 173 A / B / no		2A	2A	2A	2A	2A
4.24	Fork carriage width	b3 (mm)	920	920	920	920	920
4.31	Ground clearance under mast, with load	m1 (mm)	95	95	95	95	95
4.32	Ground clearance at centre of wheelbase, with load (forks lowered)	m2 (mm)	95	95	95	95	95
4.33	Working aisle width with 1000 x 1200 mm pallets, crosswise	Ast (mm)	3333	3333	3441	3441	3455
4.34a	Working aisle width with 800 x 1200 mm pallets, lengthwise	Ast (mm)	3456	3456	3564	3564	3579
4.35	Turning circle radius	Wa (mm)	1662	1662	1770	1770	1770
4.36	Minimum distance between centres of rotation	b13 (mm)	0	0	0	0	0
PERFORMANCE							
5.1	Travel speed, with / without load	km / h	17 / 17	17 / 17	17 / 17	17 / 17	17 / 17
5.2	Lifting speed, with / without load	m / s	0.52 / 0.62	0.46 / 0.62	0.52 / 0.62	0.46 / 0.62	0.42 / 0.62
5.3	Lowering speed, with / without load	m / s	0.56 / 0.56	0.56 / 0.56	0.56 / 0.56	0.56 / 0.56	0.56 / 0.56
5.5	Rated drawbar pull, with / without load	N	4900 / 5200	4800 / 5100	4900 / 5200	4800 / 5100	4700 / 5100
5.6	Maximum drawbar pull, with / without load (5 min short duty)	N	14900 / 15200	14900 / 15200	15000 / 15300	14900 / 15200	14800 / 15200
5.7	Gradeability, with / without load	%	15 / 25	14 / 23	15 / 26	15 / 25	12 / 21
5.8	Maximum gradeability, with / without load	%	27 / 35	26 / 35	27 / 35	26 / 35	24 / 35
5.9	Acceleration time (10 metres), with / without load	s	4.1 / 3.8	4.2 / 3.8	4.0 / 3.8	4.2 / 3.8	3.9 / 4.4
5.10	Service brakes (mechanical / hydraulic / electric / pneumatic)		Electric	Electric	Electric	Electric	Electric
ELECTRIC MOTOR							
6.1	Drive motor capacity (60 min. short duty)	kW	2 x 5.5	2 x 5.5	2 x 5.5	2 x 5.5	2 x 5.5
6.2	Lift motor output at 15% duty factor	kW	10	10	10	10	10
6.3	Battery to DIN 43 531 / 35 / 36 A / B / C / no		DIN 43531 A / no	DIN 43531 A / no	DIN 43531 A / no	DIN 43531 A / no	DIN 43531 A / no
6.4	Battery voltage / capacity at 5 - hour discharge	V / Ah	500 - 625	500 - 625	625 - 750	625 - 750	625 - 750
6.5	Battery weight	kg	679	679	812	812	812
6.6	Energy consumption according to DIN EN 16796	kWh / h	3.9	4.2	3.9	4.2	4.5
MISCELLANEOUS							
8.1	Type of drive control		AC	AC	AC	AC	AC
10.1	Maximum operating pressure for attachments	bar	210	210	210	210	210
10.2	Oil flow for attachments	l / min	30	30	30	30	30
10.7	Noise level, value at operator's ear (EN 12053)	dB (A)	65	65	65	65	65
10.8	Towing coupling, type DIN 15170		DIN15170 - H	DIN15170 - H	DIN15170 - H	DIN15170 - H	DIN15170 - H

DIMENSIONS

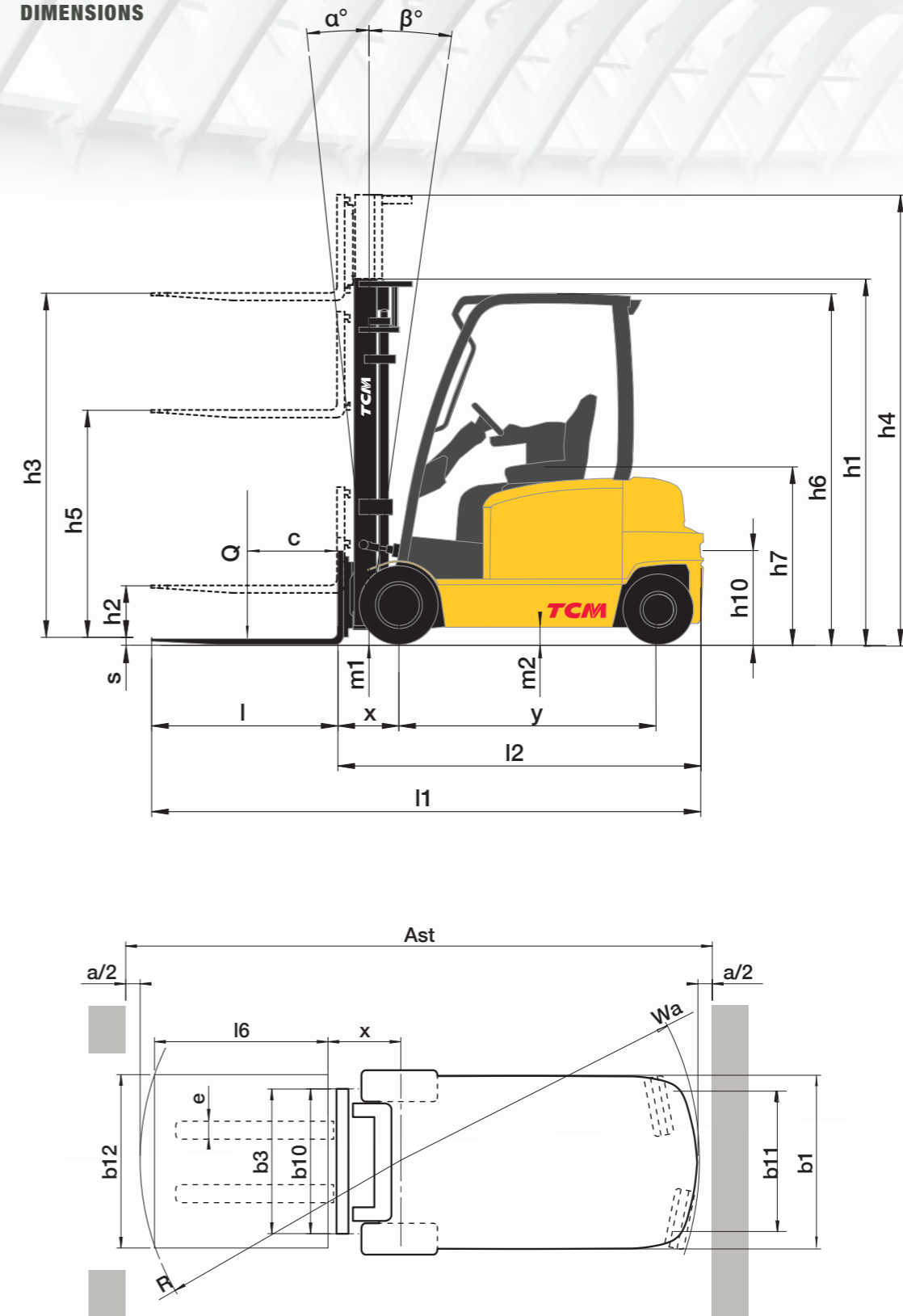

FB/FTB14-20(L)-E4

STANDARD AND OPTIONS LIST

	ALL MODELS
GENERAL	
3- and 4- wheel chassis, 48 volts, front wheel drive	●
Operator selectable economy or high performance modes ECO/PRO	●
Multi-functional colour display (Hour meter, BDI,...)	●
Lift tilt interlock and hydraulic and drive interlock / PDS	●
Tiltable steering column	●
Full electrical brakes	●
Battery compartment side door and opening battery hood cover	●
Seat Switch Timeout: all functions are disabled – truck enters 'stop mode' and park brake is automatically applied	●
Basic overhead guard	●
Trucktool setup and diagnostics	●
Intelligent brake lights	●
Dual joysticks	○
Mini steering wheel	○
ErgoLogic multi-function hydraulic control	○
Rapid sideway battery exchange chassis (SWE)	○
Chassis-integrated roller bed (FOR BATTERY SWE)	○
Special (RAL) colour for frame	○
POWER SOURCE	
Li-ion battery	○
Lead acid battery	○
HYDRAULIC	
3 valve hydraulic fingertip control mounted on adjustable armrest	●
4th & 5th hydraulic options	○
Manual lever hydraulic control	○
Hydraulic accumulator for smoother load handling on rough surface	○
Quiet hydraulic pump	●
MAST, FORKS AND CARRIAGE	
Load backrest	●
Passive sway control for mast at high lifts	●
Simplex, Duplex or Triplex masts, from 3m to 7m	○
Forks 900mm - 2000mm	○
Sideshifter W920mm	○
Integrated sideshifter W920mm	○
Integrated fork positioner with sideshift	○
Load weight indicator, in 50kg increments	○
Performance reduction from 2m to 3.5m mast (above standard)	○
DRIVE AND LIFT CONTROLS	
Variable speed control on all hydraulic functions	●
Curve control	●
Armrest direction control	●
Simulated differential lock	○
Automatic tilt centering via the F2 button on fingertip controller	○
Tilt centering second function. Two pcs. of angle memories	○
Forward-reverse direction selection lever on steering column	○
Dual pedal system - forward and reverse	○
Operator presence pedal	○
ELECTRIC	
LED working lights, 2 front and 1 rear	●
Automated reversing light	●
Automatic light switch	○
Amber strobe light	○
Road light kit	○
Electronic back-up smart alarm	○
"Blue Point" safety light, located rear and/or front	○
Red line safety lights, located on the sides	○
Pin code access	○
5V USB connector output 2x 2.5A (max. 4.4A)	○
240W, 12V power supply for accessories	○

	ALL MODELS
OHG AND CABIN	
Grammer MSG65 vinyl with seat belt switch	●
Grammer MSG65 or MSG75 with options vinyl / cloth / heater / backrest extension / Armrest (MSG65)	○
Swivel seat	○
Plexi roof cover	○
Panel cabin: Front screen with wiper + roof with crane opening	○
Panel cabin: Economy. Front screen without wiper, plexi roof cover	○
Panel cabin steel doors	○
Panel cabin rear screen	○
PVC doors	○
Heater for cabin	○
Interior package, including radio with speakers, roof lining, reading light	○
Deluxe cabin, including wind screen with wiper, roof, steel doors, heater and interior lining	○
Rear view mirror, basic / outside / wide view	○
List bracket - A4	○
Storage plastic locker	○
Sun visor	○
Accessory rack	○
RAM-mounts dummy, D-series	○
RAM-mounts computer rack, C-series	○
RAM-mounts scanner rack, C-series	○
Powder fire extinguisher	○
Narrow overhead guard for drive in racking	○
TYRES	
Solid pneumatic tyres	●
Solid non-marking tyres	○
ENVIRONMENT	
Hot area hydraulic oil, VG46	○
Cold area hydraulic oil, VG15	○
Hydraulic oil food grade	○
Bio grade oil	○
Cold store option, (to -35C)	○

KEY ● Standard ○ Option

