

TECHNICAL SPECIFICATIONS

FTB13-20-9(LB)



# FTB13-20-9(LB)

## STANDARD SPECIFICATIONS

CHARACTERISTICS			TCM Forklifts									
			FTB13-9	FTB15-9	FTB16-9	FTB18-9	FTB20-9	FTB16-9LB	FTB18-9LB	FTB20-9LB		
1.01	Manufacturer		TCM Forklifts									
1.02	Manufacturer's model designation		FTB13-9	FTB15-9	FTB16-9	FTB18-9	FTB20-9	FTB16-9LB	FTB18-9LB	FTB20-9LB		
1.03	Power source: (battery, diesel, LP gas, petrol)		Electric	Electric	Electric	Electric	Electric	Electric	Electric	Electric		
1.04	Operator type: pedestrian, (operator)-standing, -seated		Seated	Seated	Seated	Seated	Seated	Seated	Seated	Seated		
1.05	Load capacity	Q (kg)	1300	1500	1600	1800	2000	1600	1800	2000		
1.06	Load center distance	c (mm)	500	500	500	500	500	500	500	500		
1.08	Load distance, axle to fork face	x (mm)	375	375	375	375	415	375	375	415		
1.09	Wheelbase	y (mm)	1220	1320	1415	1415	1415	1525	1525	1525		
WEIGHT												
2.01	Truck weight, without load / including battery (simplex mast, lowest lift height)	kg	2625	2700	2675	2870	2345	3050	3300	3405		
2.02	Axle loading with maximum load, front/rear (simplex mast, lowest lift height)	kg	3460/465	3735/455	3820/445	4155/515	4650/595	4020/630	4315/785	4815/590		
2.03	Axle loading without load, front/rear (simplex mast, lowest lift height)	kg	1230/1395	1245/1445	1235/1430	1245/1625	1355/1890	1505/1545	1485/1815	1615/1790		
WHEELS, DRIVE TRAIN												
3.01	Tyres: V=solid, L=pneumatic, SE=solid pneumatic - front/rear		L / L	L / L	L / L	L / L	SE / L	L / L	L / L	SE / L		
3.02	Tyre dimensions, front		18x7 - 8 - 14PR	18x7 - 8 - 14PR	18x7 - 8 - 16PR	18x7 - 8 - 16PR	18x7 - 8 (N.P)*	18x7 - 8 - 16PR	18x7 - 8 - 16PR	18x7 - 8 (N.P)*		
3.03	Tyre dimensions, rear		15x4.5 - 8 - 12PR	15x4.5 - 8 - 12PR	15x4.5 - 8 - 12PR	16x6 - 8 - 10PR	16x6 - 8 - 10PR	15x4.5 - 8 - 12PR	16x6 - 8 - 10PR	16x6 - 8 - 10PR		
3.05	Number of wheels, front/rear (x=driven)		2x / 2	2x / 2	2x / 2	2x / 2	2x / 2	2x / 2	2x / 2	2x / 2		
3.06	Track width (centre of tyres), front	b10 (mm)	920	920	920	920	920	920	920	920		
3.07	Track width (centre of tyres), rear	b11 (mm)	250	250	250	230	230	250	230	230		
DIMENSIONS												
4.01	Mast tilt, forwards/backwards	α/β °	5/7.5	5/7.5	5/7.5	5/7.5	5/7.5	5/7.5	5/7.5	5/7.5		
4.02	Height with mast lowered (see tables)	h1 (mm)	1975	1975	1975	1975	1975	1975	1975	1975		
4.03	Free lift (see tables)	h2 (mm)	115	115	115	115	120	115	115	120		
4.04	Lift height (see tables)	h3 (mm)	3000	3000	3000	3000	3000	3000	3000	3000		
4.05	Overall height with mast raised	h4 (mm)	4015	4015	4015	4015	4000	4015	4015	4000		
4.07	Height to top of overhead guard	h6 (mm)	2050	2050	2050	2050	2050	2050	2050	2050		
4.08	Seat height	h7 (mm)	955	955	955	955	955	955	955	955		
4.12	Tow coupling height	h10 (mm)	575	575	575	575	575	575	575	575		
4.19	Overall length	l1 (mm)	2855	2955	3050	3105	3175	3160	3215	3255		
4.20	Length to fork face (includes fork thickness)	l2 (mm)	1785	1885	1980	2035	2105	2090	2145	2185		
4.21	Overall width	b1/b2 (mm)	1090	1090	1090	1090	1090	1090	1090	1090		
4.22	Fork dimensions (thickness, width, length)	s / e / l (mm)	35x100x1070	35x100x1070	35x100x1070	35x100x1070	40x122x1070	35x100x1070	35x100x1070	40x122x1070		
4.23	Fork carriage to DIN 15 173 A/B/no		2A	2A	2A	2A	2A	2A	2A	2A		
4.24	Fork carriage width	b3 (mm)	920	920	920	920	1000	920	920	1000		
4.31	Ground clearance under mast, with load	m1 (mm)	85	85	85	85	85	85	85	85		
4.32	Ground clearance at center of wheelbase, with load (forks lowered)	m2 (mm)	85	85	85	85	85	85	85	85		
4.33	Working aisle width with 1000 x 1200 mm pallets, crosswise	Ast (mm)	3110	3210	3305	3360	3430	3415	3470	3507		
4.34	Working aisle width with 800 x 1200 mm pallets, lengthwise	Ast (mm)	3235	3335	3430	3485	3555	3540	3595	3635		
4.35	Turning circle radius	Wa (mm)	1410	1510	1605	1660	1690	1715	1770	1770		
PERFORMANCE												
5.01	Travel speed, with/without load	km/h	15/16.5	15/16.5	14.5/16.0	14.5/16.0	14/15.5	14.5/16.0	14.5/16.0	14/15.5		
5.02	Lifting speed, with/without load	m/s	0.40 / 0.61	0.38 / 0.61	0.36 / 0.61	0.36 / 0.61	0.30 / 0.50	0.36 / 0.61	0.36 / 0.61	0.30 / 0.50		
5.03	Lowering speed, with/without load	m/s	0.55 / 0.50	0.55 / 0.50	0.55 / 0.50	0.55 / 0.50	0.55 / 0.50	0.55 / 0.50	0.55 / 0.50	0.55 / 0.50		
5.05	Rated drawbar pull, with/without load	N	N/A / 3180	N/A / 3120	N/A / 3080	N/A / 2190	N/A / 2080	N/A / 3020	N/A / 2130	N/A / 2010		
5.06	Maximum drawbar pull, with/without load (5 min short duty)	N	N/A / 7530	N/A / 7390	N/A / 6910	N/A / 6910	N/A / 7530	N/A / 6910	N/A / 7530	N/A / 7550		
5.07	Gradeability, with/without load	%	8.0 / 13	7.5 / 12.5	7.5 / 12.5	4.5 / 8.5	4.0 / 7.0	6.5 / 11	4.0 / 7.0	3.5 / 6.5		
5.08	Maximum gradeability, with/without load	%	20 / 20	18 / 20	15 / 20	15 / 20	14 / 17	15 / 20	15 / 20	14 / 17		
5.09	Acceleration time (10 metres) with/without load	s	4.7 / 4.2	4.7 / 4.0	4.7 / 4.1	4.7 / 4.1	4.9 / 4.1	4.8 / 4.2	4.9 / 4.2	4.9 / 4.1		
5.10	Service brakes (mechanical/hydraulic/electric/pneumatic)		Hydraulic	Hydraulic	Hydraulic	Hydraulic	Hydraulic	Hydraulic	Hydraulic	Hydraulic		
ELECTRIC MOTOR												
6.01	Drive motor capacity (60 min. short duty)	kW	2 x 4.5	2 x 4.5	2 x 4.5	2 x 4.5	2 x 4.5	2 x 4.5	2 x 4.5	2 x 4.5		
6.02	Lift motor output at 15% duty factor	kW	9.5	9.5	9.5	9.5	9.5	9.5	9.5	9.5		
6.03	Battery to DIN 43 531 / 35 / 36 A / B / C / no		- BS / JS	- BS / JS	- BS / JS	- BS / JS	- BS / JS	- BS / JS	- BS / JS	- BS / JS		
6.04	Battery voltage / capacity at 5 - hour discharge	V / Ah	48 / 340	48 / 350	48 / 350	48 / 420	48 / 420	48 / 730	48 / 730	48 / 730		
6.05	Battery weight	kg	550	595	595	650	650	1120	1120	1120		
MISCELLANEOUS												
8.01	Type of drive control		FET	FET	FET	FET	FET	FET	FET	FET		
8.02	Maximum operating pressure for attachments	bar	137	137	157	157	181	157	157	181		
8.03	Oil flow for attachments	l/min	60	60	60	60	50	60	60	50		
8.04	Noise level, value at operator's ear (EN 12053)	dB(A)	<75	<75	<75	<75	<75	<75	<75	<75		

\* N.P. No puncture tyre.

## DIMENSIONS FTB13-20-9(LB)

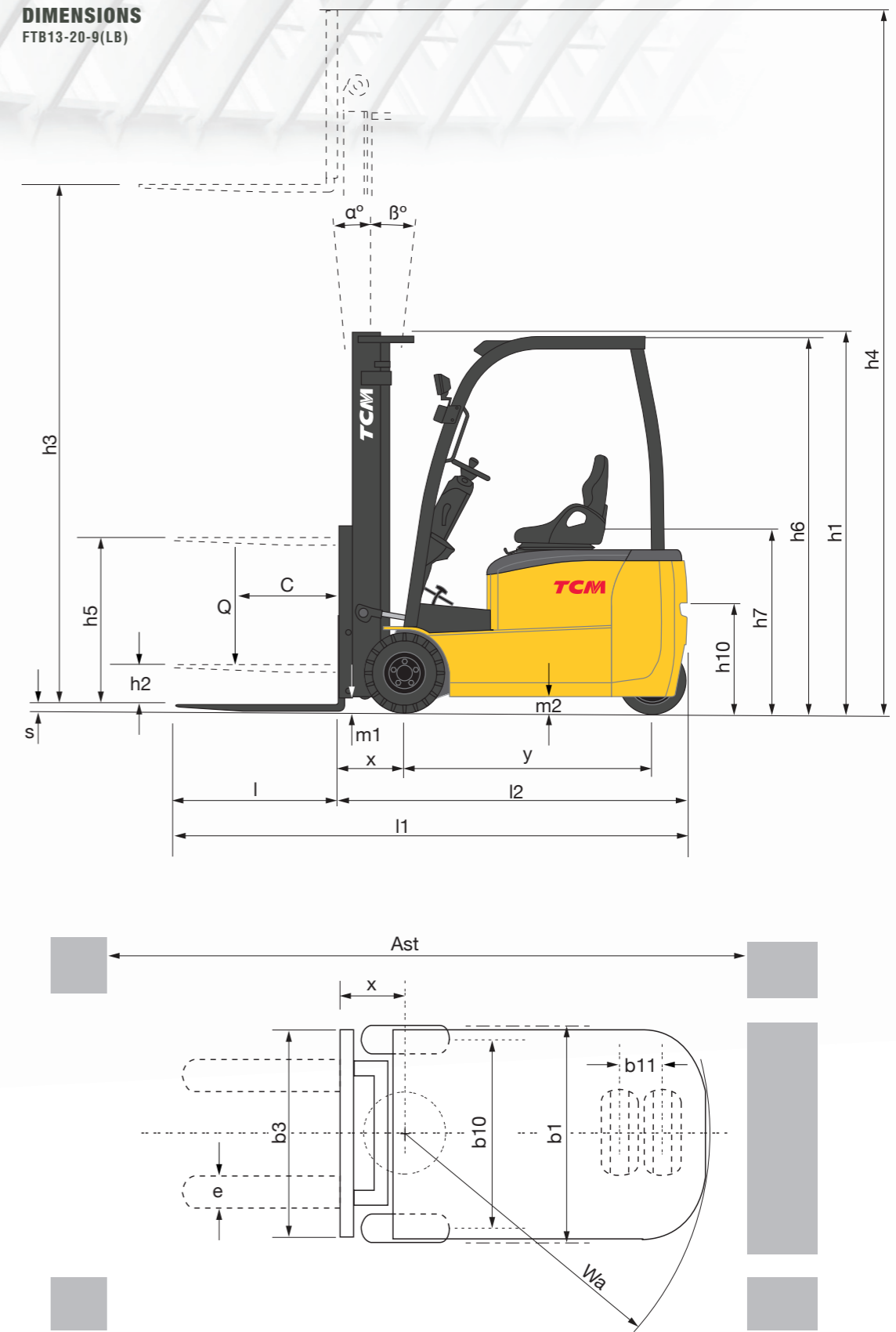

## MAST SPECIFICATIONS & RATED CAPACITIES

MAST TYPE	Max fork height (mm)	Overall mast height (mm)		Free lift* (mm)	Mast Tilt (Degrees Fwd/Bwd)	FTB13-9		FTB15-9	
		Lowered	Extended			Load Capacity (kgs) @ 500mm load centre			
						Pneumatic Tyres	Solid Tyres	Pneumatic Tyres	Solid Tyres
SIMPLEX	3000	1975	4015	115	5-7.5	1300	1300	1500	1500
	3300	2125	4315	115	5-7.5	1300	1300	1500	1500
	3500	2225	4515	115	5-7.5	1300	1300	1500	1500
	3700	2325	4715	115	5-7.5	1270	1270	1500	1500
	4000	2525	5015	115	5-7.5	1200	1230	1400	1450
	4500	2775	5515	115	3-6	1130	1150	1250	1350
	5000	3035	6015	115	3-6	900	1070	1050	1250
DUPLEX	3000	1975	4015	960	5-6	1300	1300	1500	1500
	3300	2125	4315	1110	5-6	1270	1270	1500	1500
	3500	2225	4515	1210	5-6	1270	1270	1500	1500
	3700	2325	4715	1310	5-6	1270	1270	1500	1500
	4000	2525	5015	1510	5-6	1200	1230	-	-
TRIPLEX	3700	1775	4715	760	5-6	1230	1270	-	-
	4000	1875	5015	860	5-6	1170	1230	-	-
	4300	1975	5315	960	3-6	1130	1170	1250	1400
	4500	2045	5515	1030	3-6	1070	1150	1200	1350
	4700	2125	5715	1110	3-6	1050	1130	1150	1300
	5000	2225	6015	1210	3-6	900	1070	1000	1250
	5500	2415	6515	1400	1.5-5	700	950	770	1100
	6000	2595	7015	1580	1.5-5	500	670	550	700
	6500	2835	7515	1820	1.5-4	370	450	400	470
	7000	3035	8015	2020	1.5-4	250	300	270	330

\* Free lift including load backrest (without load backrest increase by 305mm (two stage) or 465mm (three stage))

MAST TYPE	Max fork height (mm)	Overall mast height (mm)		Free lift* (mm)	Mast Tilt (Degrees Fwd/Bwd)	FTB16-9		FTB18-9	
		Lowered	Extended			Load Capacity (kgs) @ 500mm load centre			
						Pneumatic Tyres	Solid Tyres	Pneumatic Tyres	Solid Tyres
SIMPLEX	3000	1975	4015	115	5-7.5	1600	1600	1800	1800
	3300	2125	4315	115	5-7.5	1570	1570	1800	1800
	3500	2225	4515	115	5-7.5	1550	1550	1770	1770
	3700	2325	4715	115	5-7.5	1530	1530	1730	1750
	4000	2525	5015	115	5-7.5	1450	1470	1630	1670
	4500	2775	5515	115	3-6	1270	1370	1400	1600
	5000	3035	6015	115	3-6	1070	1270	1150	1450
DUPLEX	3000	1975	4015	960	5-6	1600	1600	1800	1800
	3300	2125	4315	1110	5-6	1550	1550	1800	1800
	3500	2225	4515	1210	5-6	1530	1530	1770	1770
	3700	2325	4715	1310	5-6	1530	1530	1730	1750
	4000	2525	5015	1510	5-6	1430	1470	1630	1670
TRIPLEX	3700	1775	4715	760	5-6	1470	1530	1630	1750
	4000	1875	5015	860	5-6	1400	1470	1570	1670
	4300	1975	5315	960	3-6	1130	1430	1470	1630
	4500	2045	5515	1030	3-6	1270	1370	1350	1570
	4700	2125	5715	1110	3-6	1200	1330	1270	1530
	5000	2225	6015	1210	3-6	1030	1270	1100	1470
	5500	2415	6515	1400	1.5-5	800	1130	850	1150
	6000	2595	7015	1580	1.5-5	570	730	600	750
	6500	2835	7515	1820	1.5-4	430	500	450	530
	7000	3035	8015	2020	1.5-4	300	350	330	370

\* Free lift including load backrest (without load backrest increase by 305mm (two stage) or 465mm (three stage))

## MAST SPECIFICATIONS & RATED CAPACITIES

MAST TYPE	Max fork height (mm)	Overall mast height (mm)		Free lift* (mm)	Mast Tilt (Degrees Fwd/Bwd)	FTB16-9LB		FTB18-9LB	
		Lowered	Extended			Load Capacity (kgs) @ 500mm load centre			
						Pneumatic Tyres	Solid Tyres	Pneumatic Tyres	Solid Tyres
SIMPLEX	3000	1975	4015	115	5-7.5	1600	1600	1800	1800
	3300	2125	4315	115	5-7.5	1600	1600	1800	1800
	3500	2225	4515	115	5-7.5	1600	1600	1800	1800
	3700	2325	4715	115	5-7.5	1600	1600	1800	1800
	4000	2525	5015	115	5-7.5	1600	1600	1800	1800
	4500	2775	5515	115	3-6	1430	1600	1500	1800
	5000	3035	6015	115	3-6	1130	1450	1170	1500
DUPLEX	3000	1975	4015	960	5-6	1600	1600	1800	1800
	3300	2125	4315	1110	5-6	1600	1600	1800	1800
	3500	2225	4515	1210	5-6	1600	1600	1800	1800
	3700	2325	4715	1310	5-6	1600	1600	1800	1800
	4000	2525	5015	1510	5-6	1600	1600	1800	1800
TRIPLEX	3700	1775	4715	760	5-6	1600	1600	1800	1800
	4000	1875	5015	860	5-6	1570	1600	1800	1800
	4300	1975	5315	960	3-6	1530	1550	1700	1800
	4500	2045	5515	1030	3-6	1470	1530	1530	1750
	4700	2125	5715	1110	3-6	1300	1500	1350	1700
	5000	2225	6015	1210	3-6	1130	1450	1170	1530
	5500	2415	6515	1400	1.5-5	800	1130	850	1150
	6000	2595	7015	1580	1.5-5	570	730	600	750
	6500	2835	7515	1820	1.5-4	430	500	450	530
	7000	3035	8015	2020	1.5-4	300	350	330	370

\* Free lift including load backrest (without load backrest increase by 305mm (two stage) or 465mm (three stage))

MAST TYPE	Max fork height (mm)	Overall mast height (mm)		Free lift* (mm)	Mast Tilt (Degrees Fwd/Bwd)	FTB20-9LB	FTB20-9LB
		Lowered	Extended			Load Capacity (kgs) @ 500mm load centre	
						Solid Tyres	Solid Tyres
SIMPLEX	3000	1975	4000	120	6-12	2000	2000
	3300	2125	4300	120	6-12	2000	2000
	3500	2225	4500	120	6-12	2000	2000
	3700	2325	4700	120	6-12	2000	2000
	4000	2525	5000	120	6-12	2000	2000
	4500	2775	5500	120	4-6	1800	1830
	5000	3035	6000	120	4-6	1600	1630
DUPLEX	3000	1975	4000	975	5-6	2000	2000
	3300	2125	4300	1125	5-6	2000	2000
	3500	2225	4500	1225	5-6	2000	2000
	3700	2325	4700	1325	5-6	2000	2000
	4000	2525	5000	1525	5-6	2000	2000
TRIPLEX	3700	1775	4700	775	5-6	1950	1950
	4000	1875	5000	875	5-6	1930	1930
	4300	1975	5300	975	3-6	1850	1850
	4500	2045	5500	1045	3-6	1800	1800
	4700	2125	5700	1125	3-6	1730	1730
	5000	2225	6000	1225	3-6	1600	1600
	5500	2415	6500	1415	1.5-5	1170	1170
	6000	2595	7000	1595	1.5-5	770	770
	6500	2835	7500	1835	1.5-4	550	550
	7000	3035	8000	2035	1.5-4	400	400

\* Free lift including load backrest (without load backrest increase by 305mm (two stage) or 465mm (three stage))



# FTB13-20-9(LB)

## STANDARD AND OPTIONS LIST (All models)

GENERAL	
Spare key	●
Headlight guards	●
Cold store modification	●
Rust protection	●
Quick release couplings for attachments	●
Sideways battery exchange	●
Dust protection	●
HYDRAULIC	
3-Way control valve	●
4-Way control valve	●
3 and 4 way auxiliary piping	●
Wet disk brakes	●
Regenerative brakes	●
MAST FORKS AND CARRIAGE	
1070 mm forks	●
Load backrest	●
Load backrest variations	●
Lift limit switch	●
Fork insertion laser pointer	●
Hook on sideshift	●
Integral side shift	●
Fork length variations	●
ELECTRIC	
Sicos-AC control system for traction and hydraulics	●
Operation interlock system (traction and hydraulics)	●
Rear combination lamps	●
Headlights	●
Turn signal lamps at the front overhead guard	●
Reverse buzzer	●
Rotating warning beacon	●
Electric power steering	●
OPERATOR'S COMPARTMENT	
ORS deluxe seat	●
Hour meter	●
Battery discharge indicator	●
VFD display panel with safety monitor and self diagnostics	●
Mode selection switch	●
Digital load indicator	●
Horizontal tilt display	●
Floor mat	●
Emergency switch hand brake with warning device	●
Electric Horn	●
Tilt steering column	●
Rear view mirror	●
TYRES	
Dual rear tyres	●

**KEY** ● Standard ● Option

