

TECHNICAL SPECIFICATIONS

FD180-230-2



STANDARD SPECIFICATIONS

CHARACTERISTICS			TCM Forklifts			
			FD180-2	FD200-2	FD230-2	
1.01	Manufacturer					
1.02	Manufacturer's model designation					
1.03	Power source: (battery, diesel, LPG, petrol)		Diesel	Diesel	Diesel	
1.04	Operator type: pedestrian, standing, seated		Seated	Seated	Seated	
1.05	Load capacity	Q (kg)	18000	20000	23000	
1.06	Load centre distance	c (mm)	900	900	900	
1.08	Load distance, axle to fork face	x (mm)	925	925	925	
1.09	Wheelbase	y (mm)	3650	3650	3650	
WEIGHT						
2.01	Truck weight, without load / including battery (simplex mast, lowest lift height)		kg	25040	27260	30760
2.02	Axle loading with maximum load, front/rear (simplex mast, lowest lift height)		kg	38770 / 4270	42580 / 4680	48330 / 5430
2.03	Axle loading without load, front/rear (simplex mast, lowest lift height)		kg	11770 / 13270	12580 / 14680	13710 / 17050
WHEELS, DRIVE TRAIN						
3.01	Tyres: V=solid, L=pneumatic, SE=solid pneumatic - front/rear		L / L	L / L	L / L	
3.02	Tyre dimensions, front			13.00-24-20PR	14.00-24-24PR	14.00-24-24PR
3.03	Tyre dimensions, rear			13.00-24-20PR	14.00-24-24PR	14.00-24-24PR
3.05	Number of wheels, front/rear (x=driven)			4x / 2	4x / 2	4x / 2
3.06	Track width (centre of tyres), front	b10 (mm)		2195	285	2185
3.07	Track width (centre of tyres), rear	b11 (mm)		2340	2300	2300
DIMENSIONS						
4.01	Mast tilt, forwards/backwards		α/β °	6/12	6/12	6/12
4.02	Height with mast lowered (see tables)		h1 (mm)	3545	3575	3580
4.03	Free lift		h2 (mm)	0	0	0
4.04	Lift height (see tables)		h3 (mm)	3000	3000	3000
4.05	Overall height with mast raised		h4 (mm)	5040	5070	5080
4.07	Height to top of overhead guard		h6 (mm)	3230	3260	3260
4.08	Seat height		h7 (mm)	2180	2210	2210
4.12	Tow coupling height		h10 (mm)	760	790	790
4.19	Overall length		l1 (mm)	7205	7205	7990
4.20	Length to fork face (includes fork thickness)		l2 (mm)	5365	5365	5545
4.21	Overall width		b1 (mm)	2990	3060	3060
4.22	Fork dimensions (thickness, width, length)		s / e / l (mm)	100 x 260 x 1830	100 x 260 x 1830	98 x 310 x 2440
4.23	Fork carriage to DIN 15 173 A/B/no			No	No	No
4.24	Fork carriage width		b3 (mm)	2750	2750	2750
4.31	Ground clearance under mast, with load		m1 (mm)	270	300	290
4.32	Ground clearance at center of wheelbase, with load (forks lowered)		m2 (mm)	325	355	355
4.33	Working aisle width with 1000 x1200 mm pallets, crosswise		Ast (mm)	7125	7275	7495
4.34	Working aisle width with 800 x1200 mm pallets, crosswise		Ast (mm)	6925	7075	7295
4.34a	Working aisle width with 800 x1200 mm pallets, lengthwise		Ast (mm)	7325	7475	7695
4.35	Turning circle radius		Wa (mm)	5000	5150	5350
4.36	Minimum distance between centres of rotation		b13 (mm)	1720	1950	1950
PERFORMANCE						
5.01	Travel speed, with/without load		km/h	/ 34	/ 34	/ 32
5.02	Lifting speed, with/without load		m/s	0.29 / 0.31	0.285 / 0.31	0.26 / 0.24
5.03	Lowering speed, with/without load		m/s	0.4 / 0.6	0.4 / 0.6	0.4 / 0.6
5.06	Maximum drawbar pull, with/without load (5 min short duty)		N	119000 / 68000	113000 / 70000	113000 / 76000
5.07	Gradeability, with/without load		%	20 / 25	17.9 / 23.8	15.2 / 23.3
5.10	Service brakes (mechanical/hydraulic/electric/pneumatic)			Pneumatic-Hydraulic	Pneumatic-Hydraulic	Pneumatic-Hydraulic
IC ENGINE						
7.01	Manufacturer / Type			ISUZU 6BG1T	ISUZU 6BG1T	ISUZU 6BG1T
7.02	Rated / Nominal output to ISO 1585**		kW	125	125	125
7.03	Rated speed to DIN 70 020		rpm	2200	2200	2200
7.04	Number of cylinders / cubic capacity		cm³	6 / 6494	6 / 6494	6 / 6494
7.06	Max torque		Nm	620	620	620
7.07	Max torque at engine speed		rpm	1800	1800	1800
MISCELLANEOUS						
8.01	Type of drive control			Powershift 3/3	Powershift 3/3	Powershift 3/3
8.02	Maximum operating pressure for attachments		bar	206	206	206
8.03	Oil flow for attachments		l/min	260	260	260

DIMENSIONS FD180-230-2

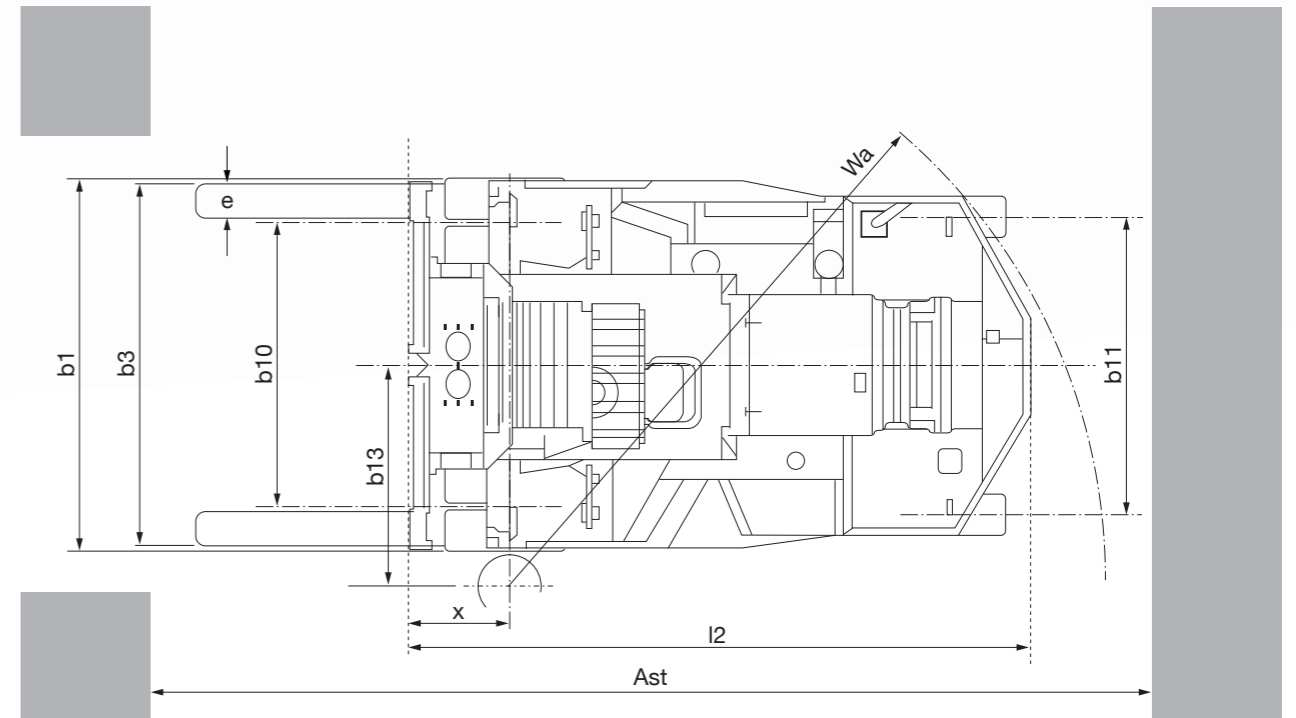
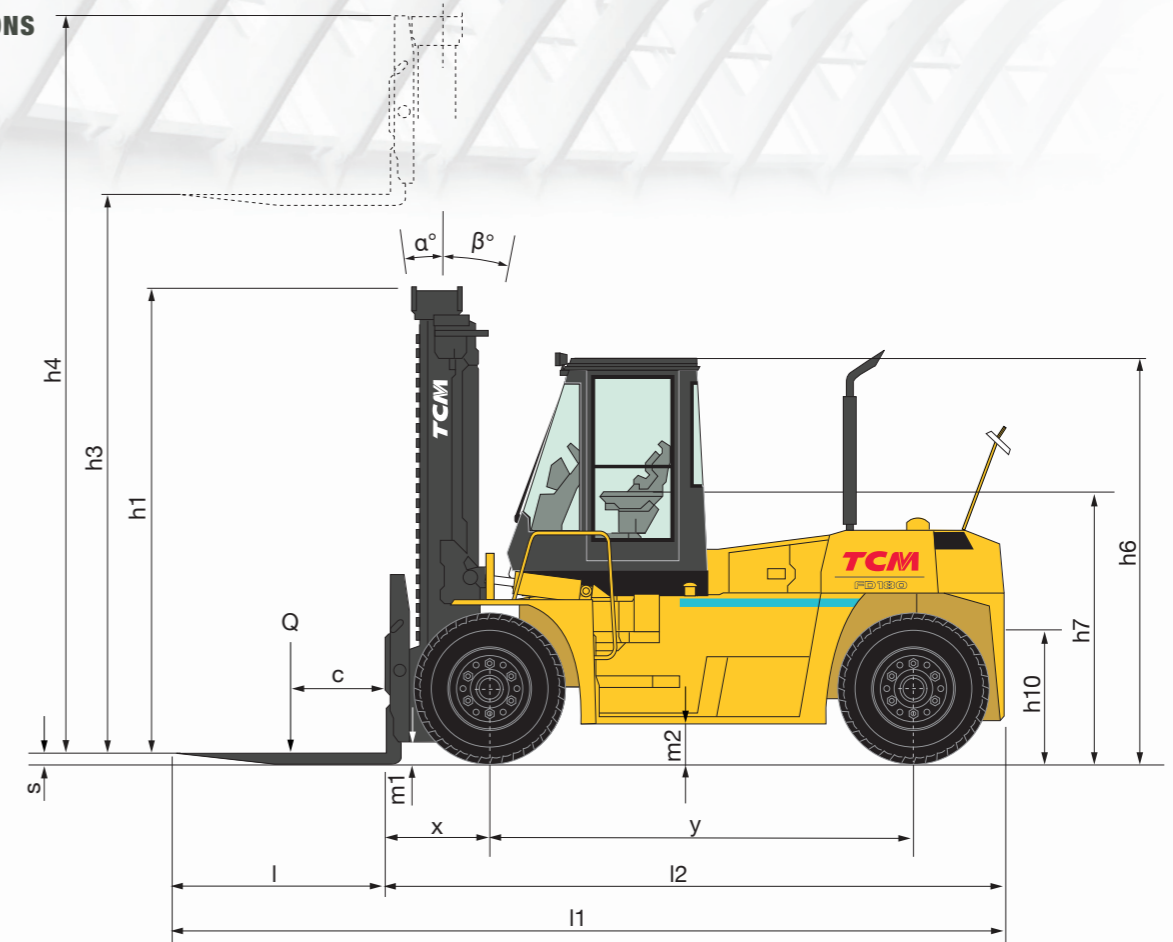

MAST SPECIFICATIONS & RATED CAPACITIES

MAST TYPE	Max fork height (mm)	Overall mast height (mm)		Mast Tilt (Degrees Fwd/Bwd)	FD180-2	
		Lowered	Extended		Load Capacity (kgs) @ 500mm load centre	
					900	1220
SIMPLEX	3000	3540	5040	6-12	18000	15500
	3500	3790	5540	6-12	18000	15500
	4000	4040	6040	6-12	18000	15500
	4500	4290	6540	6-12	18000	15500
	5000	4540	7040	6-12	18000	15500
	5500	4790	7540	6-12	16000	14000
	6000	5040	8040	6-12	15000	13000

MAST TYPE	Max fork height (mm)	Overall mast height (mm)		Mast Tilt (Degrees Fwd/Bwd)	FD200-2	
		Lowered	Extended		Load Capacity (kgs) @ 500mm load centre	
					900	1220
SIMPLEX	3000	3570	5070	6-12	20000	18000
	3500	3820	5570	6-12	20000	18000
	4000	4070	6070	6-12	20000	18000
	4500	4320	6570	6-12	20000	18000
	5000	4570	7070	6-12	20000	18000
	5500	4820	7570	6-12	18000	16000
	6000	5070	8070	6-12	16000	14500

MAST TYPE	Max fork height (mm)	Overall mast height (mm)		Mast Tilt (Degrees Fwd/Bwd)	FD230-2	
		Lowered	Extended		Load Capacity (kgs) @ 500mm load centre	
					900	1220
SIMPLEX	3000	3580	5080	6-12	23000	20000
	3500	3830	5580	6-12	23000	20000
	4000	4080	6080	6-12	23000	20000
	4500	4330	6580	6-12	23000	20000
	5000	4580	7080	6-12	23000	20000
	5500	4830	7580	6-12	21500	19000
	6000	5080	8080	6-12	20000	18000



STANDARD AND OPTIONS LIST

	FD180-F2	FD200-F2	FD230-F2
GENERAL			
Cyclopack type double element	●	●	●
Electric horn and back-up buzzer	●	●	●
Hydraulic/pneumatic, with power booster and with air dryer	●	●	●
Coolant recovery system	●	●	●
Drawbar pin	●	●	●
Diesel engine with turbo charger	●	●	●
Engine auto glow and after glow system	●	●	●
Cylinder type bonnet latch	●	●	●
Overhead muffler	●	●	●
Cartridge type air, fuel, engine oil, converter oil and hydraulic filters. Engine oil dipstick	●	●	●
With oil gauge (view level)	●	●	●
2 way mechanical levers with lift cut-off valve, load check valve and tilt lock valve	●	●	●
LED headlight / turn signal lamps / rear combination lamps / rear reflectors	●	●	●
Rear view mirrors and rear under-view mirror	●	●	●
Wet disc type brakes	●	●	●
Tilt adjustable steering column	●	●	●
Interlock for travelling, lifting & tilting	●	●	●
Adjustable swivel suspension seat with seat belt	●	●	●
Operator tool kit	●	●	●
Automatic 3-speed powershift transmission. Torque converter oil dipstick	●	●	●
Front dual pneumatic tires, rear single pneumatic tyres	●	●	●

	FD180-F2	FD200-F2	FD230-F2
OPERATORS COMPARTMENT			
Steel cabin	●	●	●
Air conditioner	●	●	●
Heater & defroster	●	●	●
Direction change lever at right hand	●	●	●
Windshield with wiper	●	●	●
ACCESSORIES			
High volume backup buzzer	●	●	●
Headlight / turn signal lamps / rear combination lamps (LED)	●	●	●
LED rear work light	●	●	●
Front working lamps on fender (LED)	●	●	●
SAFETY DEVICES			
Front working lamps on fender (LED)	●	●	●
Central lubrication system	●	●	●
Fire extinguisher	●	●	●
Interlock for travelling, lifting & tilting	●	●	●
Seat belt interlock	●	●	●
ATTACHMENTS			
Side shifter integral type (shaft-on type)	●	●	●
Fork positioner hydraulic cylinder type	●	●	●
Fork positioner with side shifter hydraulic cylinder type	●	●	●

KEY ● Standard ● Option