

PRELIMINARY

TECHNICAL SPECIFICATIONS

PAL16-20(F)(E)(R)-N3



STANDARD SPECIFICATIONS PRELIMINARY

CHARACTERISTICS			PAL16F-N3	PAL18F-N3	PAL20F-N3
1.1	Manufacturer		TCM	TCM	TCM
1.2	Manufacturer's model designation		PAL16F-N3	PAL18F-N3	PAL20F-N3
1.3	Power source		Battery	Battery	Battery
1.4	Operator type		Pedestrian	Pedestrian	Pedestrian
1.5	Load capacity	Q (kg)	1600	1800	2000
1.6	Load center distance	c (mm)	600	600	600
1.8	Load wheel axle to fork face (forks lowered)	x (mm)	960	960	960
1.9	Wheelbase	y (mm)	1360	1425	1425
WEIGHT					
2.1b	Truck weight without load, with maximum battery weight	kg	430	500	500
2.2	Axle loadings with nominal load & maximum battery weight, drive / load side	kg	745 / 1290	805 / 1495	840 / 1660
2.3	Axle loadings without load & with maximum battery weight, drive / load side	kg	340 / 90	380 / 120	380 / 120
WHEELS, DRIVE TRAIN					
3.1	Tyres		Vulkollan	Vulkollan	Vulkollan
3.2	Tyre dimensions, drive side	(mm)	230 x 70	230 x 70	230 x 70
3.3	Tyre dimensions, load side	(mm)	85 x 90	85 x 75	85 x 75
3.4	Castor wheel dimensions (diameter x width)	(mm)	100 x 40	100 x 40	100 x 40
3.5	Number of wheels, load / drive side (x = driven)		2 + 1x / 2	2 + 1x / 4	2 + 1x / 4
3.6	Track width (center of tyres), drive side	b10 (mm)	480	480	480
3.7	Track width (center of tyres), load side	b11 (mm)	375	375	375
DIMENSIONS					
4.4	Lift height	h3 (mm)	135	135	135
4.9	Height of tiller arm/steering console (min / max)	h14 (mm)	865 / 1420	865 / 1420	865 / 1420
4.15	Fork height, fully lowered	h13 (mm)	85	85	85
4.19	Overall length	l1 (mm)	1650	1710	1710
4.2	Length to fork face	l2 (mm)	500	560	560
4.21	Overall width	b1 / b2 (mm)	720	720	720
4.22	Fork dimensions (thickness, width, length)	s / e / l (mm)	56 / 165 / 1150	56 / 165 / 1150	56 / 165 / 1150
4.25	Outside width over forks (minimum / maximum)	b5 (mm)	540	540	540
4.32	Ground clearance at center of wheelbase, (forks lowered)	m2 (mm)	30	30	30
4.33c	Working aisle width (Ast) with 1000 x 1200 mm pallets, load crosswise, platform up/down	Ast (mm)	2339	2475	2472
4.34c	Working aisle width (Ast3) with 800 x 1200 mm pallets, load lengthwise, platform up / down	Ast (mm)	2176	2281	2281
4.35	Turning radius	Wa (mm)	1510	1551	1551
PERFORMANCE					
5.1	Travel speed, with / without load	km / h	6.0 / 6.0	6.0 / 6.0	6.0 / 6.0
5.2	Lifting speed, with / without load	m / s	0.035 / 0.045	0.030 / 0.035	0.04 / 0.05
5.3	Lowering speed, with / without load	m / s	0.05 / 0.05	0.06 / 0.042	0.05 / 0.06
5.7	Gradeability, with / without load	%	10.0 / 20.0	10.0 / 20.0	10.0 / 20.0
5.10	Service brakes (mechanical / hydraulic / electric / pneumatic)		Electric	Electric	Electric
ELECTRIC MOTORS					
6.1	Drive motor capacity (60 min. short duty)	kW	1	1	1
6.2	Lift motor output at 15% duty factor	kW	0.8	0.8	1.2
6.4	Battery voltage/capacity at 5-hour discharge	V / Ah	24 / 150	24 / 250	24 / 250 - 375 ¹⁾
6.5	Battery weight	kg	150	210	210
6.6a	Energy consumption according to EN16796	kWh/h	0.23	0.26	0.26
MISCELLANEOUS					
8.1	Type of drive control		Stepless	Stepless	Stepless
10.7	Level of noise at the ear level of the driver according to EN 12 053:2001 and EN ISO 4871 in work LpAZ	dB (A)	64	64	64
10.7.1	Level of noise at the ear level of the driver according to EN 12 053:2001 and EN ISO 4871, drive/lift/idle LpAZ	dB (A)	66 / 70	66 / 70	66 / 70
10.7.2	Whole-body vibration (EN 13 059:2002)		-	-	-
10.7.3	Hand-arm vibration (EN 13 059:2002)		< 2.5	< 2.5	< 2.5

1) With 375Ah battery the l2 dimension increases 72 mm

DIMENSIONS

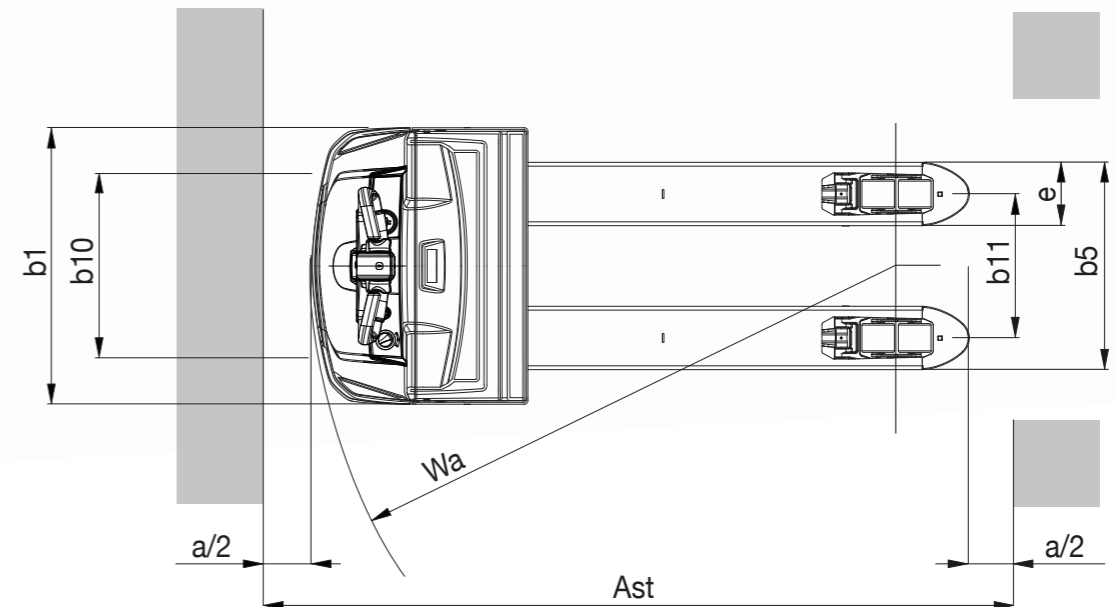
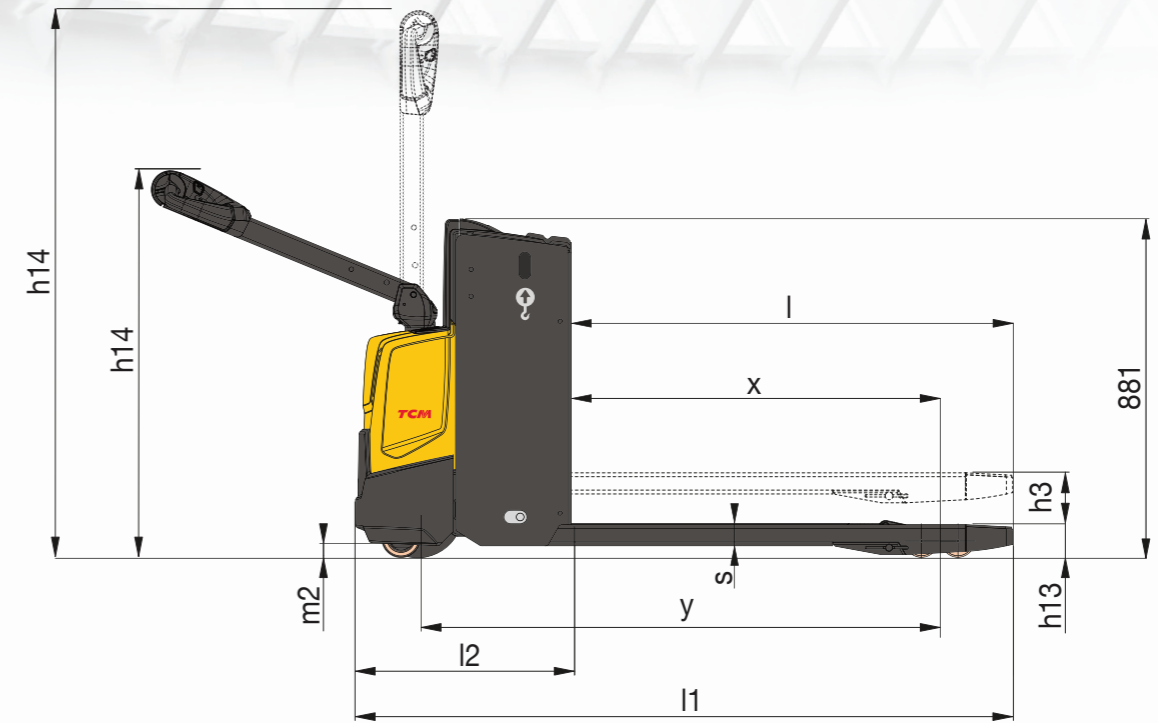

STANDARD SPECIFICATIONS PRELIMINARY

CHARACTERISTICS				PAL20E-N3
1.1	Manufacturer			TCM
1.2	Manufacturer's model designation			PAL20E-N3
1.3	Power source			Battery
1.4	Operator type			Pedestrian
1.5	Load capacity	Q	(kg)	2000 / 700
1.6	Load center distance	c	(mm)	600
1.8	Load wheel axle to fork face (forks lowered)	x	(mm)	890
1.9	Wheelbase	y	(mm)	1425
WEIGHT				
2.1b	Truck weight without load, with maximum battery weight		kg	585
2.2	Axle loadings with nominal load & maximum battery weight, drive / load side		kg	435 / 150
2.3	Axle loadings without load & with maximum battery weight, drive / load side		kg	420 / 160
WHEELS, DRIVE TRAIN				
3.1	Tyres			Vulkollan
3.2	Tyre dimensions, drive side		(mm)	230 x 70
3.3	Tyre dimensions, load side		(mm)	85 x 75
3.4	Castor wheel dimensions (diameter x width)		(mm)	100 x 40
3.5	Number of wheels, load / drive side (x = driven)			2 + 1x / 4
3.6	Track width (center of tyres), drive side	b10	(mm)	480
3.7	Track width (center of tyres), load side	b11	(mm)	375
DIMENSIONS				
4.4	Lift height	h3	(mm)	135 / 645
4.9	Height of tiller arm/steering console (min / max)	h14	(mm)	865 / 1420
4.15	Fork height, fully lowered	h13	(mm)	85
4.19	Overall length	l1	(mm)	1780
4.2	Length to fork face	l2	(mm)	630
4.21	Overall width	b1 / b2	(mm)	720
4.22	Fork dimensions (thickness, width, length)	s / e / l	(mm)	59 / 184 / 1150
4.25	Outside width over forks (minimum / maximum)	b5	(mm)	570
4.32	Ground clearance at center of wheelbase, (forks lowered)	m2	(mm)	30
4.33c	Working aisle width (Ast) with 1000 x 1200 mm pallets, load crosswise, platform up/down	Ast	(mm)	2365
4.34c	Working aisle width (Ast3) with 800 x 1200 mm pallets, load lengthwise, platform up / down	Ast	(mm)	2275
4.35	Turning radius	Wa	(mm)	1560
PERFORMANCE				
5.1	Travel speed, with / without load		km / h	6.0 / 6.0
5.2	Lifting speed, with / without load		m / s	0.11 / 0.14
5.3	Lowering speed, with / without load		m / s	0.13 / 0.12
5.7	Gradeability, with / without load		%	9.0 / 20.0
5.10	Service brakes (mechanical / hydraulic / electric / pneumatic)			Electric
ELECTRIC MOTORS				
6.1	Drive motor capacity (60 min. short duty)		kW	1
6.2	Lift motor output at 15% duty factor		kW	1.2
6.4	Battery voltage/capacity at 5-hour discharge		V / Ah	24 / 150
6.5	Battery weight		kg	151
6.6a	Energy consumption according to EN16796		kWh/h	
6.6b	Energy consumption according to VDI 60 cycle		kWh/h	
MISCELLANEOUS				
8.1	Type of drive control			Stepless
10.7	Level of noise at the ear level of the driver according to EN 12 053:2001 and EN ISO 4871 in work LpAZ		dB (A)	64
10.7.1	Level of noise at the ear level of the driver according to EN 12 053:2001 and EN ISO 4871, drive/lift/idle LpAZ		dB (A)	66 / 70
10.7.2	Whole-body vibration (EN 13 059:2002)			-
10.7.3	Hand-arm vibration (EN 13 059:2002)			< 2.5

DIMENSIONS

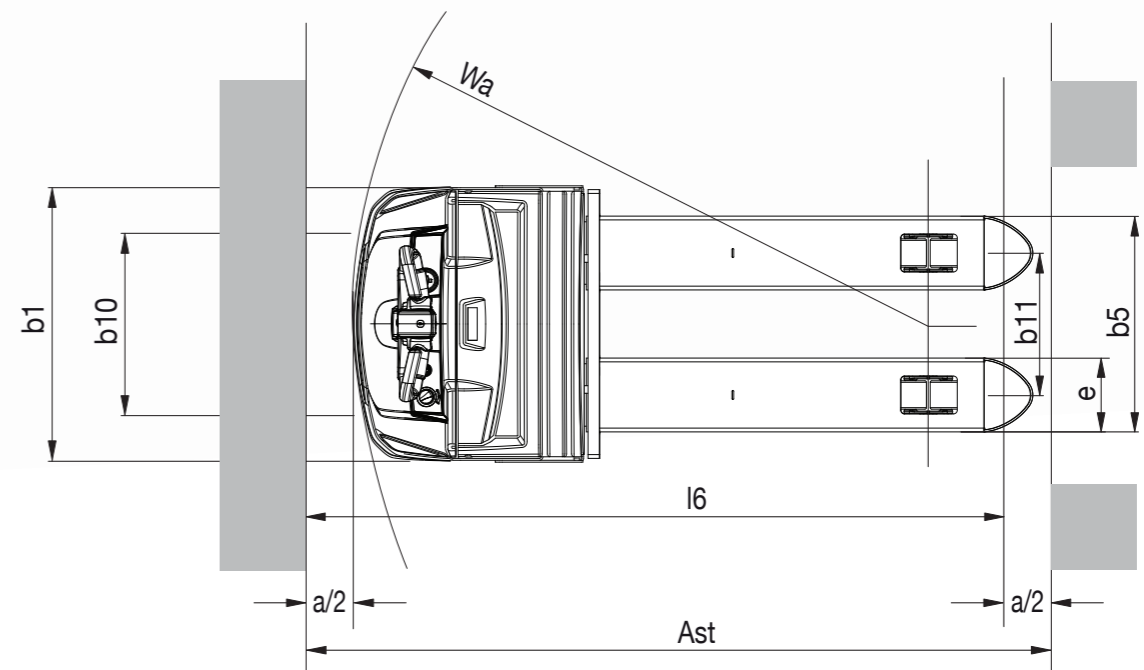
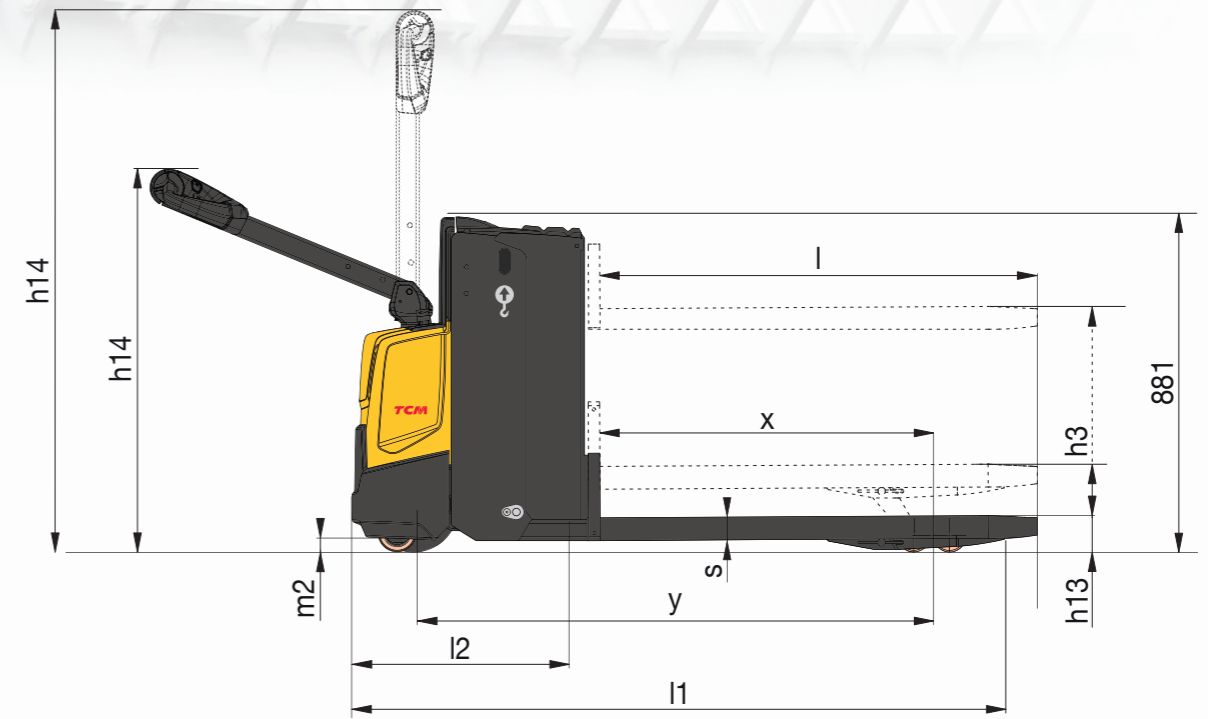

STANDARD SPECIFICATIONS PRELIMINARY

CHARACTERISTICS			PAL20R-N3
1.1	Manufacturer		TCM
1.2	Manufacturer's model designation		PAL20R-N3
1.3	Power source		Battery
1.4	Operator type		Pedestrian
1.5	Load capacity	Q (kg)	2000
1.6	Load center distance	c (mm)	600
1.8	Load wheel axle to fork face (forks lowered)	x (mm)	960
1.9	Wheelbase	y (mm)	1420
WEIGHT			
2.1b	Truck weight without load, with maximum battery weight	kg	640
2.2	Axle loadings with nominal load & maximum battery weight, drive / load side	kg	950 / 1710
2.3	Axle loadings without load & with maximum battery weight, drive / load side	kg	505 / 135
WHEELS, DRIVE TRAIN			
3.1	Tyres		Vulkollan
3.2	Tyre dimensions, drive side	(mm)	230 x 70
3.3	Tyre dimensions, load side	(mm)	85 x 75
3.4	Castor wheel dimensions (diameter x width)	(mm)	125 x 55
3.5	Number of wheels, load / drive side (x = driven)		2 + 1x / 4
3.6	Track width (center of tyres), drive side	b10 (mm)	480
3.7	Track width (center of tyres), load side	b11 (mm)	375
DIMENSIONS			
4.4	Lift height	h3 (mm)	135
4.8	Seat- or stand height	h7 (mm)	170
4.9	Height of tiller arm/steering console (min / max)	h14 (mm)	1155 / 1550
4.15	Fork height, fully lowered	h13 (mm)	85
4.19	Overall length	l1 (mm)	1850 / 2345
4.2	Length to fork face	l2 (mm)	700 / 1195
4.21	Overall width	b1 / b2 (mm)	720
4.22	Fork dimensions (thickness, width, length)	s / e / l1 (mm)	50 / 165 / 1150
4.25	Outside width over forks (minimum / maximum)	b5 (mm)	540
4.32	Ground clearance at center of wheelbase, (forks lowered)	m2 (mm)	30
4.33c	Working aisle width (Ast) with 1000 x 1200 mm pallets, load crosswise, platform up/down	Ast (mm)	2504 / 2984
4.34c	Working aisle width (Ast3) with 800 x 1200 mm pallets, load lengthwise, platform up / down	Ast (mm)	2416 / 2896
4.35	Turning radius	Wa (mm)	1680 / 2160
PERFORMANCE			
5.1	Travel speed, with / without load	km / h	6.0 / 6.0
5.2	Lifting speed, with / without load	m / s	0.04 / 0.04
5.3	Lowering speed, with / without load	m / s	0.05 / 0.06
5.7	Gradeability, with / without load	%	9.0 / 20.0
5.10	Service brakes (mechanical / hydraulic / electric / pneumatic)		Electric
ELECTRIC MOTORS			
6.1	Drive motor capacity (60 min. short duty)	kW	1
6.2	Lift motor output at 15% duty factor	kW	1.2
6.4	Battery voltage/capacity at 5-hour discharge	V / Ah	24 / 250 - 375 ¹⁾
6.5	Battery weight	kg	212 - 294
6.6a	Energy consumption according to EN16796	kWh/ h	
6.6b	Energy consumption according to VDI 60 cycle	kWh/ h	
MISCELLANEOUS			
8.1	Type of drive control		Stepless
10.7	Level of noise at the ear level of the driver according to EN 12 053:2001 and EN ISO 4871 in work LpAZ	dB (A)	60
10.7.1	Level of noise at the ear level of the driver according to EN 12 053:2001 and EN ISO 4871, drive/lift/idle LpAZ	dB (A)	63 / 65
10.7.2	Whole-body vibration (EN 13 059:2002)		0.9
10.7.3	Hand-arm vibration (EN 13 059:2002)		< 2.5

1) With 375Ah battery the l2 dimension increases 72 mm

DIMENSIONS

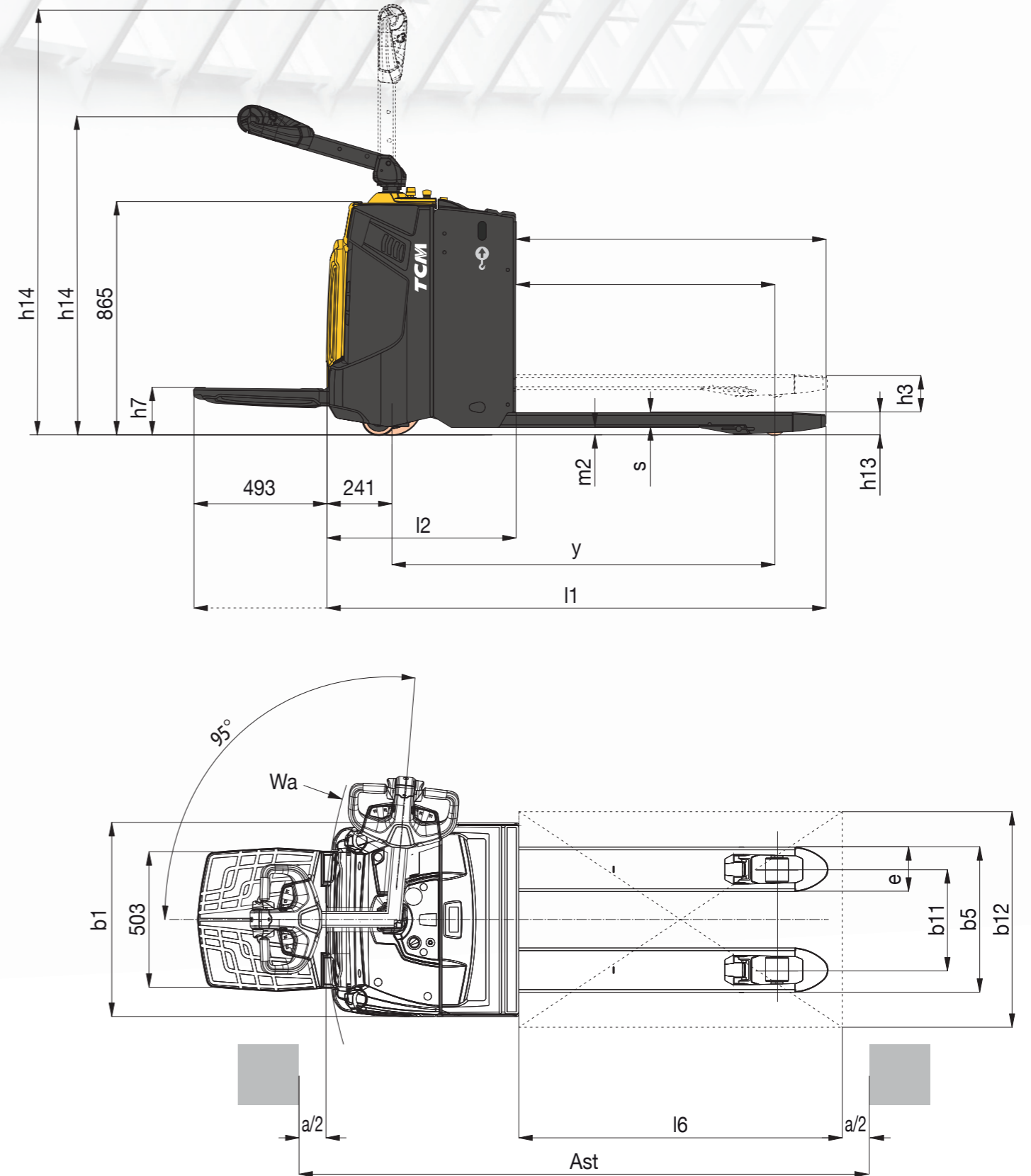

PAL16-20(F)(E)(R)-N3

STANDARD AND OPTIONS LIST

	PAL16F-N3	PAL18-20F-N3	PAL20E-N3	PAL20R-N3
GENERAL				
Battery discharge indicator	●	●	●	●
PIN code login 4 codes	○	○	○	○
Multi-functional display with hour meter	○	○	○	○
Electric on/off valve for lifting and lowering, controlled by rocker switch on tiller head	●	●	●	●
Initial lift	-	-	●	-
Foldable platform	-	-	-	●
Single or tandem load wheels polyurethane	●	●	●	●
Li-ION batteries	○	○	○	○
ENVIRONMENT				
Cold store design, 0°C to -30°C	○	○	○	○
Hot operating condition modification, >30°C	○	○	○	○
DRIVE AND LIFT CONTROLS				
Tiller up drive	○	○	○	○
WHEEL OPTIONS				
Polyurethane traction and load wheels	●	●	●	●
Power friction traction wheel	○	○	○	○
Tandem Polyurethane load wheels	○	●	●	●
Single Polyurethane load wheels	○	●	●	●
OTHER OPTIONS				
Key switch	●	●	●	●
Load backrest	○	○	○	○
Pallet entry and exit rollers	○	○	○	○
Special RAL colour	○	○	○	○
Inbuilt charger, 30A	○	○	○	○
Sideways battery change, 250Ah and 375Ah battery only	-	○	-	○
Battery changing device	-	○	-	○
Accessory rack	○	○	○	○
Working light	○	○	○	○

KEY ● Standard ○ Option - Not available

